

TEMPS CALME

design Studio ROCHE BOBOIS

rochebobo
PARIS



TEMPS CALME

design Studio ROCHE BOBOIS

rochebobois
PARIS



TEMPS CALME

design Studio ROCHE BOBOIS

rochebobo
PARIS

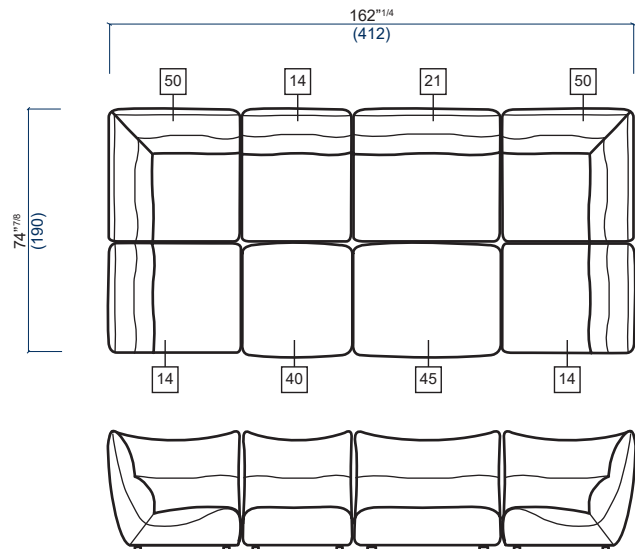

14 Chauffeuse
Armless chair
Chauffeuse

40 Pouf carré
Square ottoman
Puf cuadrado

50 Angle carré
Square corner
Angulo cuadrado

21 Chauffeuse
Armless chair
Chauffeuse

45 Pouf rectangulaire
Rectangular ottoman
Puf rectangular

TEMPS CALME

design Studio ROCHE BOBOIS

rochebobois
PARIS



FICHE TECHNIQUE / TECHNICAL SPECIFICATIONS / FICHA TECNICA:

Structure : Sapin massif, multiplis de pin, panneaux de particules (CARB)
Suspension : Sangles élastiques
Garnissage assise Chauffeuse, Angle carré et Chaise longue : Mousse polyuréthane bi-densité 35-35 soft kg/m³ et ouate polyester
Garnissage assise Pouf : Mousse polyuréthane densité 35 kg/m³ et ouate polyester
Garnissage dossier : Mousse polyuréthane bi-densité 23-35 soft kg/m³ et fibre polyester
Piétement : Hêtre massif verni teinté Wengé

Structure: Solid fir wood, pine plywood, engineered composite wood (CARB)
Suspension: Elastic straps
Armless chair, Square corner and Lounge chair seat cushion: Bi-density polyurethane foam 35-35 soft kg/m³ and polyester batting
Ottoman seat cushion: Polyurethane foam 35 kg/m³ and polyester batting
Back cushion: Bi-density polyurethane foam 23-35 soft kg/m³ and polyester fibre
Base: Solid beech wood with varnish stain finish, col. Wenge

Estructura: Abeto macizo, multilaminado de pino, paneles de partículas (CARB)
Suspensión: Cinchas elásticas
Interior asiento Chauffeuse, Angulo cuadrado y Chaise longue: Espuma poliuretano bi-densidad 35-35 soft kg/m³ y guata poliéster
Interior asiento Puf: Espuma poliuretano densidad 35 soft kg/m³ y guata poliéster
Interior respaldo: Espuma poliuretano bi-densidad 23-35 soft kg/m³ y fibra poliéster
Patas: Haya maciza barniz tintado Wengué

OBSERVATIONS / OBSERVATIONS / OBSERVACIONE:

- Fabrication Européenne
- Entièrement déshabillable
- Modèle réalisable dans tous les tissus de la collection Roche Bobois à l'exception des tissus à motifs ou à rayures (avec raccords), des velours de coton et des tissus Douceur et Câlin
- Modèle non réalisable en cuir

- Manufactured in Europe
- Entirely removable covers
- This model is available in all fabrics from the Roche Bobois collection, with the exception of striped and patterned fabrics (with repeat), cotton velvets, Douceur and Câlin fabric
- This model is not available in leather

- Fabricación europea
- Completamente desenfundable
- Modelo realizable en todas las telas de la colección Roche Bobois, excepto con las telas con motivos y rayadas (con raccords), los terciopelos de algodón y las telas Douceur y Câlin
- Modelo no realizable en piel

OPTIONS / OPTIONAL / OPCIONES:

- Coutures disponibles dans 3 versions (voir page 5) :
 - fil tressé gris foncé, col. 160
 - fil tressé gris clair, col. 723
 - fil épais ton sur ton (par défaut sur les tissus à bouclettes)

- Stitching available in 3 versions (see page 5):
 - braided thread, col. 160 dark grey
 - braided thread, col. 723 light grey
 - tone-on-tone thick thread (by default on fabrics with curls)

- Costuras disponibles en 3 versiones (ver página 5):
 - hilo trenzado, gris oscuro, col. 160
 - hilo trenzado, gris claro, col. 723
 - hilo grueso, tono sobre tono (de forma predeterminada para las telas con rizos)

CHOIX DE COUTURES / STITCHING OPTIONS / ELECCION DE COSTURAS

Il est possible de choisir entre 3 versions de couture :

- fil tressé gris foncé, col. 160
- fil tressé gris clair, col. 723
- fil épais ton sur ton (par défaut sur les tissus à bouclettes)

Three versions of stitching available:

- braided thread, col. 160 dark grey
- braided thread, col. 723 light grey
- tone-on-tone thick thread (by default on fabrics with curls)

Es posible elegir entre 3 tipos de costuras:

- hilo trenzado, gris oscuro, col. 160
- hilo trenzado, gris claro, col. 723
- hilo grueso, tono sobre tono (de forma predeterminada para las telas con rizos)



FIL TRESSÉ GRIS FONCÉ, COL. 160
BRAIDED THREAD, COL. 160 DARK GREY
HILO TRENZADO, GRIS OSCURO, COL. 160



FIL TRESSÉ GRIS CLAIR, COL. 723
BRAIDED THREAD, COL. 723 LIGHT GREY
HILO TRENZADO, GRIS CLARO, COL. 723



EXEMPLE DE FIL ÉPAIS TON SUR TON
EXAMPLE OF TONE-ON-TONE THICK THREAD
EJEMPLO DE HILO GRUESO, TONO SOBRE TONO

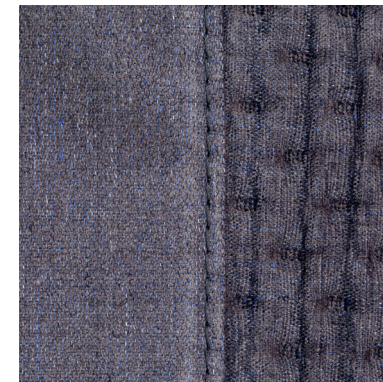

14 Chauffeuse
Armless chair
Chauffeuse

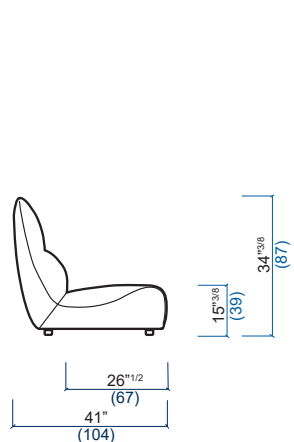

21 Chauffeuse
Armless chair
Chauffeuse

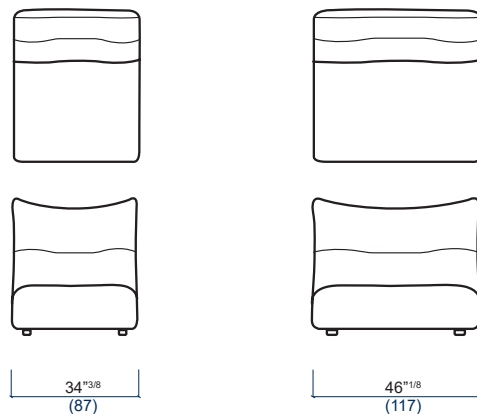

54 Chaise longue
Lounge chair
Chaise longue

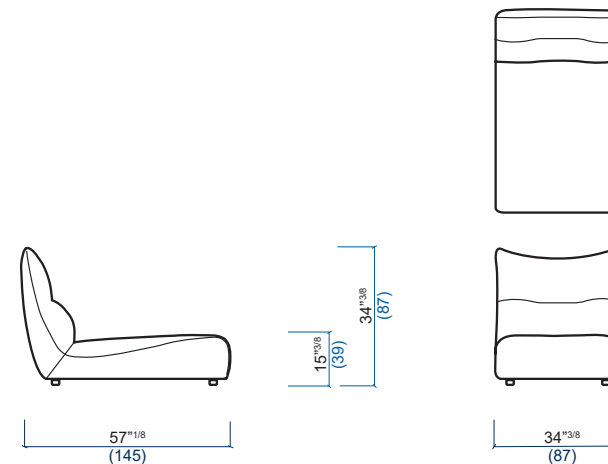

50 Angle carré
Square corner
Angulo cuadrado

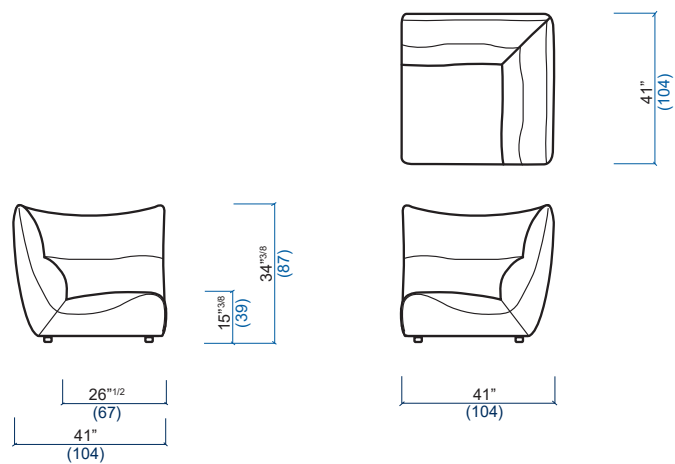

TEMPS CALME

design Studio ROCHE BOBOIS

rochebobo
PARIS

40 Pouf carré
Square ottoman
Puf cuadrado

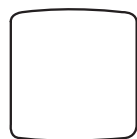

34^m³/₈
(87)

15^m³/₈
(39)

45 Pouf rectangulaire
Rectangular ottoman
Puf rectangular



34^m³/₈
(87)

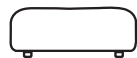

34^m³/₈
(87)

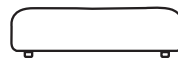

46^m¹/₈
(117)

99 Coussin carré
Square cushion
Cojín cuadrado



15^m³/₄
(40)

15^m³/₄
(40)

98 Coussin rectangulaire
Rectangular cushion
Cojín rectangular



21^m³/₄
(55)

15^m³/₄
(40)

97 Cale-reins
Lumbar cushion
Rifionera



25^m⁵/₈
(65)

9^m¹/₈
(23)