

# Collection ASTER

design Reda Amalou



**rochebobo**  
P A R I S



Le nombre de répétition d'un superbe Y en frêne massif permet d'adapter la taille du piétement à celle du plateau souhaité. Une idée graphique et mathématique du designer franco-algérien Reda Amalou.

The multiple solid ash Y-shaped pieces allows you to adapt the base to support any size top. This graphic and mathematical table was designed by French-Algerian designer Reda Amalou.

El número de repeticiones de una magnífica Y en ceniza macizo, permite adaptar la medida de la pata a la del sobre deseado. Una idea gráfica y matemática del diseñador franco-argelino Reda Amalou.

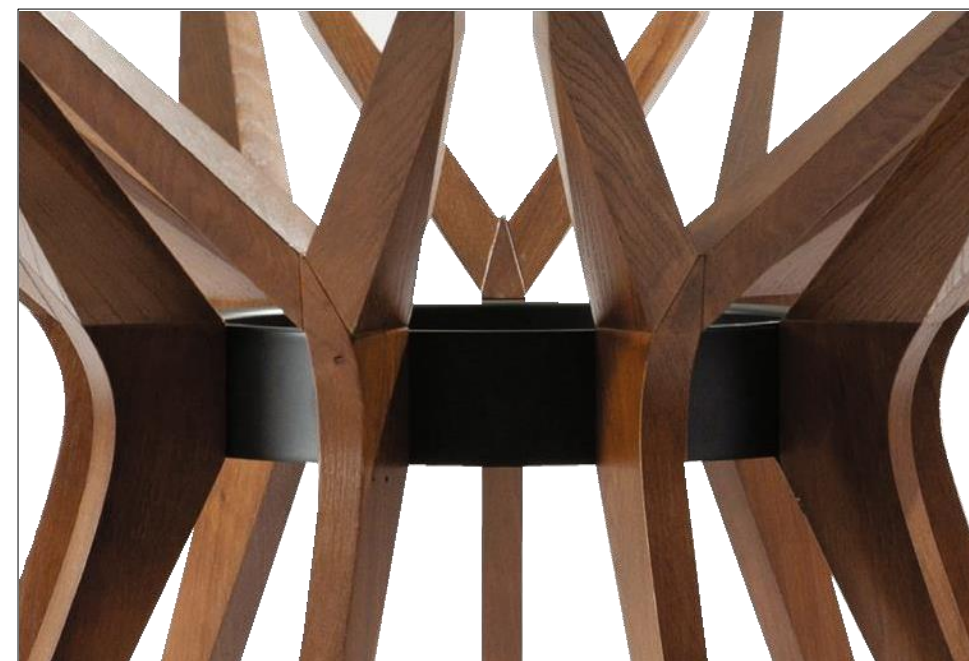

## TABLES DE REPAS / TABLE BASSE / BOUT DE CANAPÉ / SELLETTES

Piètement en frêne massif finition naturel ou teinté, vernis satiné.

Teintes : Alezan, Gravier, Bruyère, Taupe, Wengé, Gris ardoise, Blanchi... Anneau métal, finition epoxy noir (sauf sellettes).

Verre trempé ep. 12 mm.

## DINING TABLES / COFFEE TABLE / END TABLE / PEDESTAL

Solid ash structure natural or tinted finishing, satin varnish.

Tint: Alezan, Gravier, Bruyère, Taupe, Wengé, Gris ardoise, Blanchi ... Metal ring, black epoxy finishing (except pedestals).

Tempered glass thickness 0.05"

## MESAS DE COMEDOR / MESA DE CENTRO / MESA DE RINCÓN / VELADORES

Patas de ceniza macizo acabado natural o tintado, barniz satinado. Color: Alezan, Gravier, Bruyère,

Taupe, Wengé, Gris ardoise, Blanchi ... Anillo de metal, acabado epoxy negro (excepto veladores).

Cristal templado espesor 12 mm.

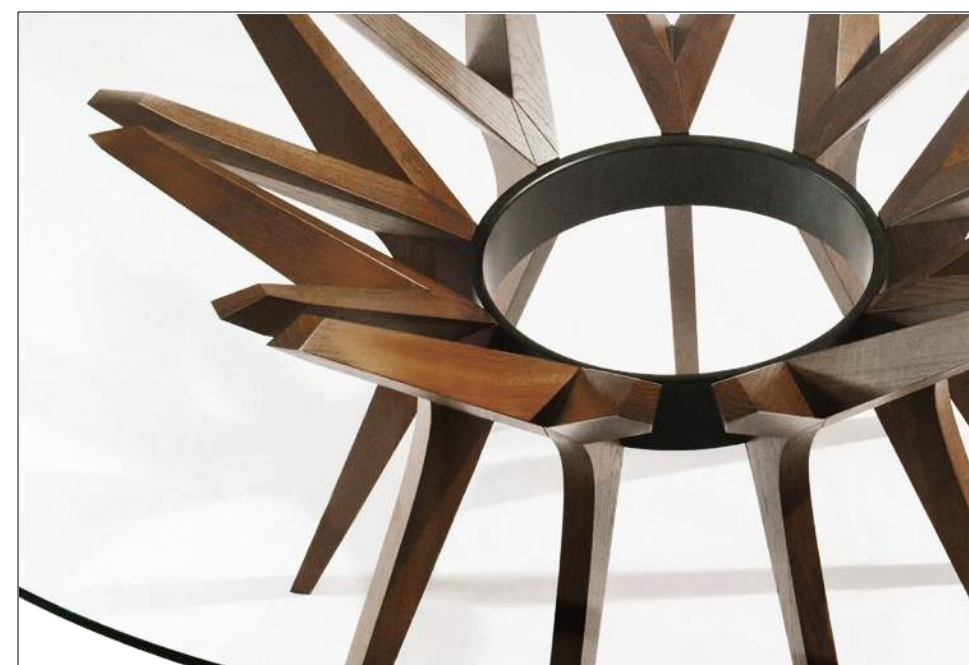

# Collection ASTER



design Reda Amalou

**rochebobo**  
PARIS

TABLES DE REPAS  
DINING TABLES  
MESAS DE COMEDOR

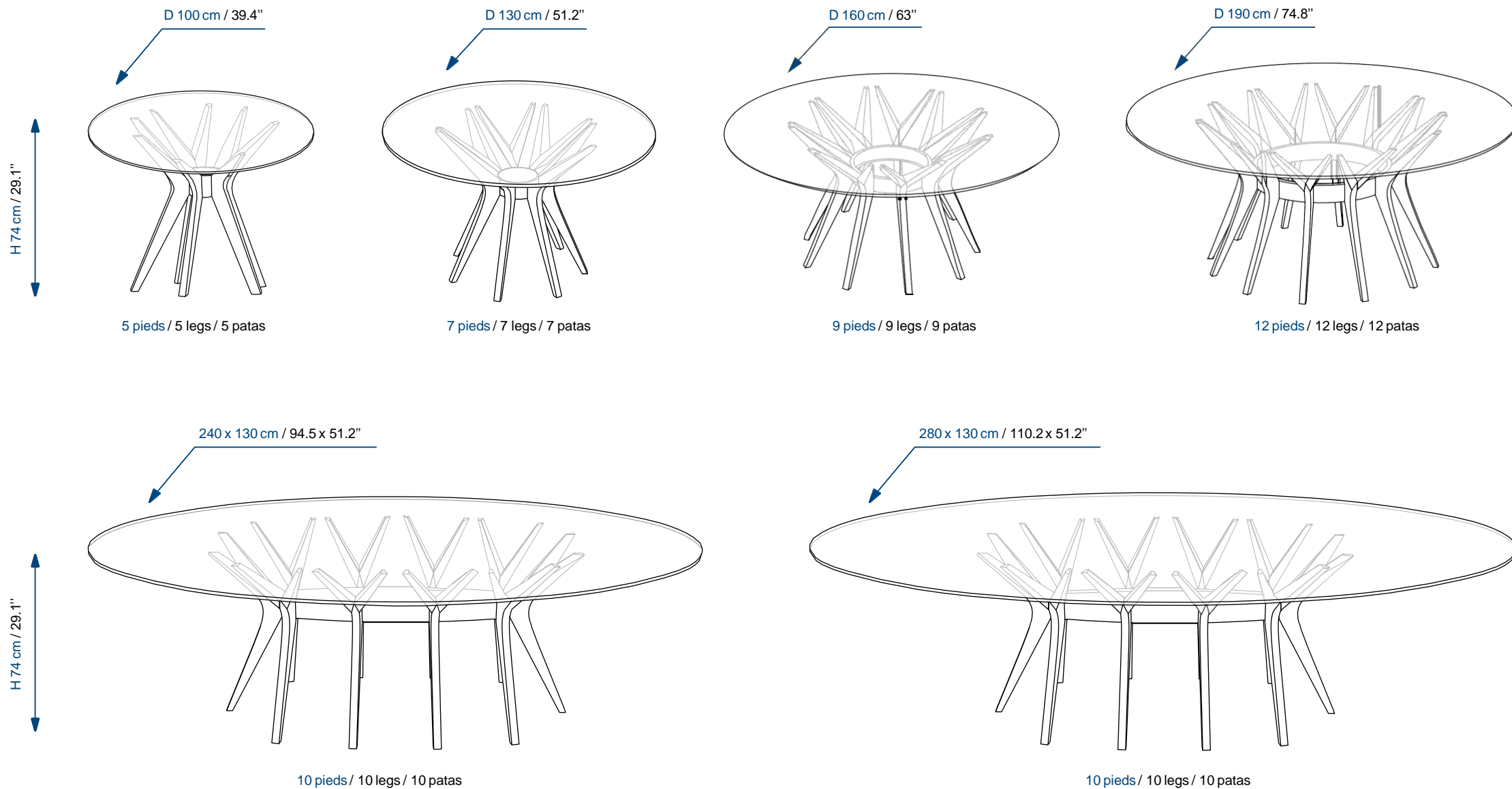

# Collection ASTER

design Reda Amalou



**rochebobo**  
PARIS



TABLE BASSE  
COFFEE TABLE  
MESA DE CENTRO

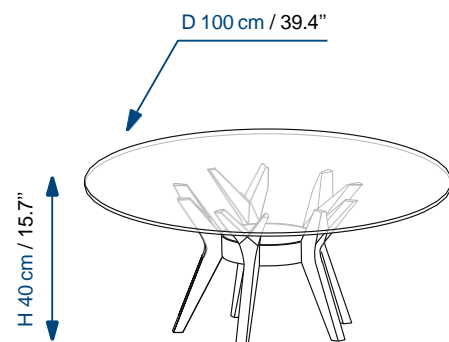

BOUT DE CANAPÉ  
END TABLE  
MESA DE RINCÓN

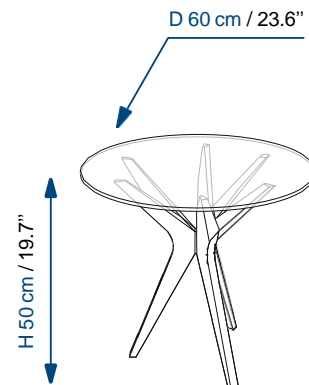

SELLETTES  
PEDESTAL  
VELADORES

