

EDITO CANAPE / SOFA

design Sacha LAKIC

rochebobois
PARIS



EDITO CANAPE / SOFA

rochebobois
PARIS

design Sacha LAKIC

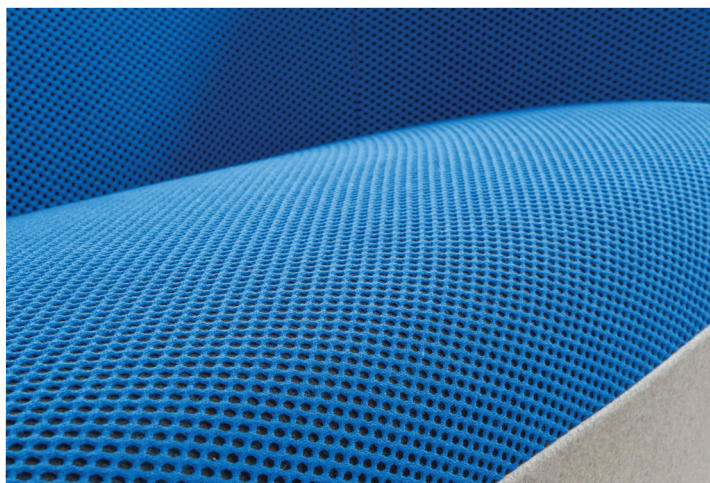
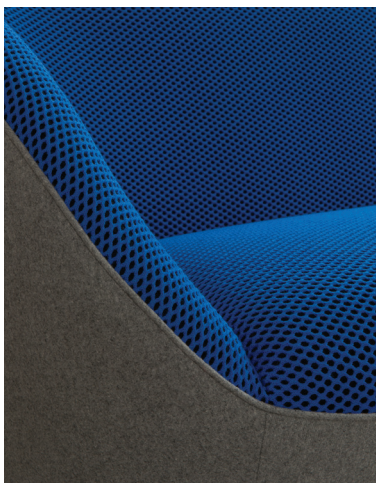

FICHE TECHNIQUE / TECHNICAL SPECIFICATIONS / FICHA TECNICA:

Structure : Sapin massif et multiplis de pin
Suspension : Sangles élastiques HR
Garnissage assise : Mousse polyuréthane HR densité 40 kg/m³ et fibre polyester
Garnissage dossier : Mousse polyuréthane HR densité 45 kg/m³ et fibre polyester
Piétement : Hêtre massif verni teinté Wengé

Structure: Solid fir wood and pine plywood
Suspension: HR elastic straps
Seat cushion: HR polyurethane foam 40 kg/m³ and polyester fibre
Back cushion: HR polyurethane foam 45 kg/m³ and polyester fibre
Base: Solid beech wood with varnish stain finish, col. Wenge

Estructura: Abeto macizo y multilaminado de pino
Suspensión: Cinchas elásticas HR
Interior asiento: Espuma poliuretano HR densidad 40 kg/m³ y fibra poliéster
Interior respaldo: Espuma poliuretano HR densidad 45 kg/m³ y fibra poliéster
Patatas: Haya maciza barniz tintado Wengué

OBSERVATIONS / OBSERVATIONS / OBSERVACIONES :

- Fabrication Européenne
- Petite profondeur
- Modèle réalisable en cuir et dans l'ensemble des tissus de la collection Roche Bobois à l'exception des cuirs d'épaisseur supérieure ou égale à 1,6 mm, des tissus à motifs et à rayures (avec raccords), des velours, des microfibras, des tissus épais, des tissus et cuirs rigides, des faux cuirs et des tissus nécessitant un traitement non-feu
- Manufactured in Europe
- Small depth
- Model available in leather and in all fabrics from the Roche Bobois collection, with the exception of leathers with thickness equals of more than 1,6 mm, striped and patterned fabrics (with repeat), velvets, microfibers, thick fabrics, stiff fabrics and leathers, leather-like fabrics, or fabrics that need fireproof treatment
- Fabricación europea
- Pequeña profundidad
- Modelo realizable en piel y en todas las telas de la colección Roche Bobois, excepto con pieles de un grosor superior o igual a 1,6 mm, las telas con motivos o rayadas (con racords), los terciopelos, las microfibras, las telas gruesas, telas y pieles rígidas, falsas pieles y telas que necesiten un tratamiento ignífugo

OPTIONS / OPTIONAL / OPCIONES:

- Passepoil disponible en différents versions. Voir pages 3 et 4
- Piping available in different versions. See pages 3 and 4 for details
- Ribete disponible en diferentes versiones. Ver páginas 3 y 4

EDITO CANAPE / SOFA

design Sacha LAKIC

INFORMATIONS SUR PASSEPOIL / INFORMATION ABOUT PIPING / INFORMACIONES SOBRE RIBETE

VERSION EN TISSU / FABRIC VERSION / VERSION EN TELA

VERSION STANDARD

PASSEPOIL IDEM TISSU EXTERIEUR
PIPING MATCHING EXTERIOR FABRIC
RIBETE COMO TELA EXTERIOR

INT. | EXT.

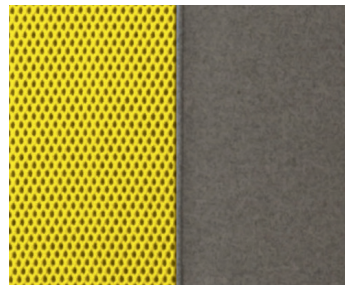

INTERIEUR ET EXTERIEUR
EN TISSU
INTERIOR AND EXTERIOR
IN FABRIC
INTERIOR Y EXTERIOR
EN TELA

VERSION 01

PASSEPOIL IDEM TISSU INTERIEUR
PIPING MATCHING INTERIOR FABRIC
RIBETE COMO TELA INTERIOR

INT. | EXT.

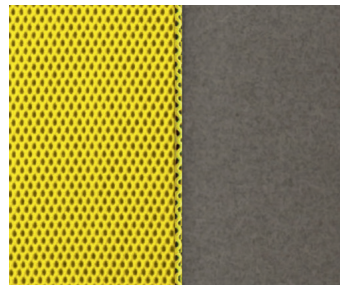

VERSION 02

PASSEPOIL NOIR
BLACK PIPING
RIBETE NEGRO

INT. | EXT.

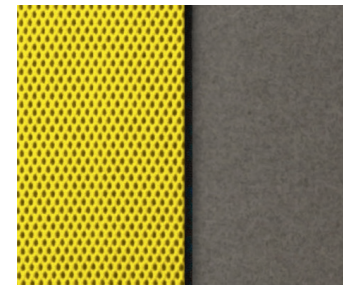

VERSION 03

PASSEPOIL EN LAINE EDITO
LAINE EDITO PIPING
RIBETE EN LAINE EDITO

INT. | EXT.

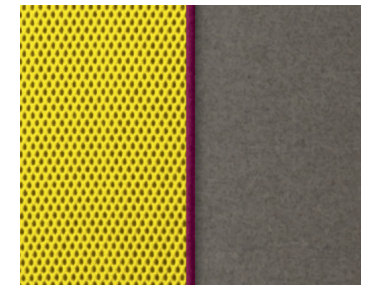

VERSION EN CUIR ET TISSU / LEATHER AND FABRIC VERSION / VERSION EN PIEL Y TELA

VERSION STANDARD

PASSEPOIL IDEM CUIR EXTERIEUR
PIPING MATCHING EXTERIOR LEATHER
RIBETE COMO PIEL EXTERIOR

INT. | EXT.

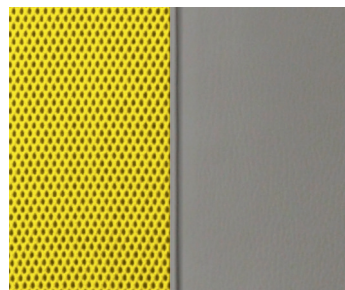

INTERIEUR EN TISSU
EXTERIEUR EN CUIR
INTERIOR IN FABRIC
EXTERIOR IN LEATHER
INTERIOR EN TELA
EXTERIOR EN PIEL

VERSION 01

PASSEPOIL IDEM TISSU INTERIEUR
PIPING MATCHING INTERIOR FABRIC
RIBETE COMO TELA INTERIOR

INT. | EXT.

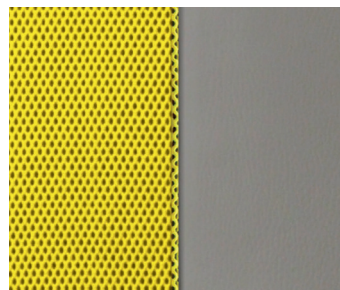

VERSION 02

PASSEPOIL NOIR
BLACK PIPING
RIBETE NEGRO

INT. | EXT.

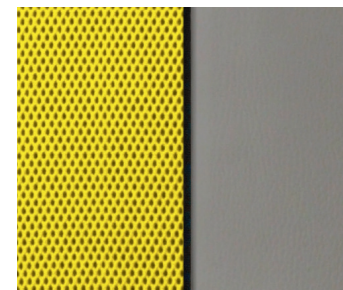

VERSION 03

PASSEPOIL EN LAINE EDITO
LAINE EDITO PIPING
RIBETE EN LAINE EDITO

INT. | EXT.

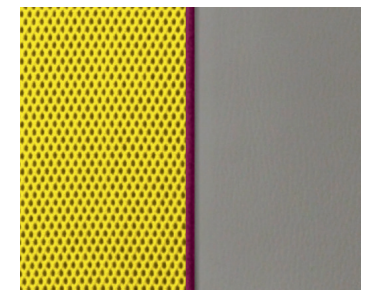

design Sacha LAKIC

INFORMATIONS SUR PASSEPOIL / INFORMATION ABOUT PIPING / INFORMACIONES SOBRE RIBETE

VERSION EN CUIR / LEATHER VERSION / VERSION EN PIEL

VERSION STANDARD

PASSEPOIL IDEM CUIR EXTERIEUR
PIPING MATCHING EXTERIOR LEATHER
RIBETE COMO PIEL EXTERIOR

INT. | EXT.

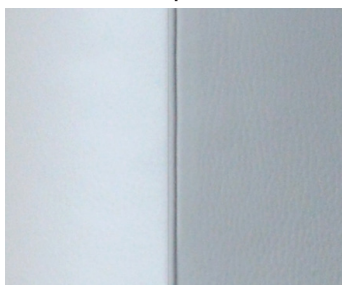

INTERIEUR ET EXTERIEUR
EN CUIR

INTERIOR AND EXTERIOR
IN LEATHER

INTERIOR Y EXTERIOR
EN PIEL

VERSION 01

PASSEPOIL IDEM CUIR INTERIEUR
PIPING MATCHING INTERIOR LEATHER
RIBETE COMO PIEL INTERIOR

INT. | EXT.

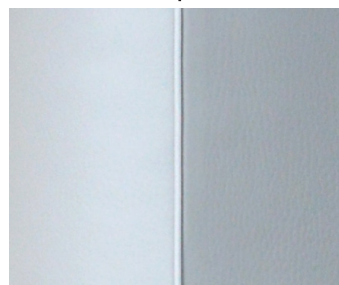

VERSION EN CUIR TRINIDAD / TRINIDAD LEATHER VERSION / VERSION EN PIEL TRINIDAD

VERSION STANDARD

PASSEPOIL EN CUIR TRINIDAD IDEM COLORIS EXTERIEUR
PIPING IN TRINIDAD LEATHER, COLOUR MATCHING EXTERIOR
RIBETE EN PIEL TRINIDAD, COLOR COMO EXTERIOR

INT. | EXT.

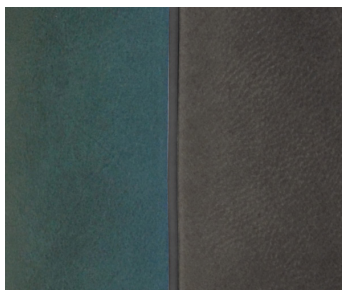

INTERIEUR ET EXTERIEUR
EN CUIR TRINIDAD

INTERIOR AND EXTERIOR
IN TRINIDAD LEATHER

INTERIOR Y EXTERIOR
EN PIEL TRINIDAD

VERSION 01

PASSEPOIL EN CUIR TRINIDAD IDEM COLORIS INTERIEUR
PIPING IN TRINIDAD LEATHER, COLOUR MATCHING INTERIOR
RIBETE EN PIEL TRINIDAD, COLOR COMO INTERIOR

INT. | EXT.

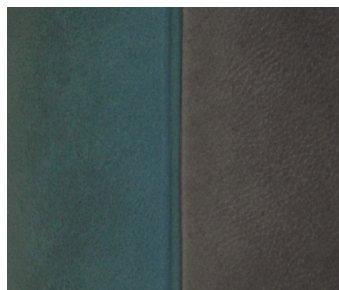

VERSION 04

PASSEPOIL EN CUIR TRINIDAD (8 COLORIS AU CHOIX)
PIPING IN TRINIDAD LEATHER (AVAILABLE IN 8 COLOURS)
RIBETE EN PIEL TRINIDAD (DISPONIBLES EN 8 COLORES)

INT. | EXT.

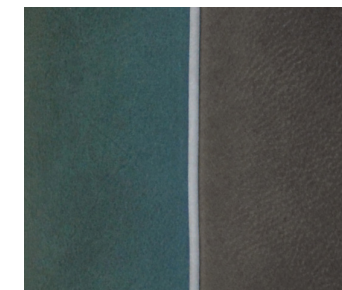

EDITO CANAPE / SOFA

rochebobois
PARIS

design Sacha LAKIC



A. INTERIEUR A 3 COUTURES

REVESTIMENT INTERIEUR EN TISSU TECHNO 2D/3D/4D,
MARSHMALLOW MATELASSE ET ORSETTO FLEX

A. INTERIOR WITH THREE STITCHING

INTERIOR UPHOLSTERED IN TECHNO 2D/3D/4D FABRIC,
MARSHMALLOW MATELASSE FABRIC AND ORSETTO FLEX FABRIC

A. INTERIOR CON 3 COSTURAS

REVESTIMIENTO INTERNO EN TELA TECHNO 2D/3D/4D,
MARSHMALLOW MATELASSE Y ORSETTO FLEX



B. INTERIEUR A 7 COUTURES

REVESTIMENT INTERIEUR EN CUIR OU AUTRES TISSUS

B. INTERIOR WITH SEVEN STITCHING

INTERIOR UPHOLSTERED IN LEATHER OR OTHER FABRICS

B. INTERIOR CON 7 COSTURAS

REVESTIMIENTO INTERNO EN PIEL U OTRAS TELAS

Présenté au départ en tissu Techno 3D, ce modèle est maintenant réalisable dans différents cuirs ou tissus.

Cependant, les cuirs et les tissus n'étant pas extensibles, il est indispensable d'ajouter des coutures dans la partie intérieure du dossier afin d'assurer une meilleure finition.

IMPORTANT : cette contrainte technique ne permet pas l'utilisation des cuirs d'épaisseur supérieure ou égale à 1,6 mm, des tissus à motifs et à rayures (avec raccord), des velours, des microfibras, des tissus épais, des tissus et cuirs rigides, des faux cuirs et des tissus nécessitant un traitement non-feu.

First shown in Techno 3D fabric, this model is now available in both leather and fabric.

However, since neither fabric nor leather are expandable, it is necessary to add stitching in the interior of the back in order to ensure a better finish.

PLEASE NOTE: this technical issue does not allow us to upholster it with leathers with thickness equals of more than 1,6 mm, striped and patterned fabrics (with repeat), velvets, microfibras, thick fabrics, stiff fabrics and leathers, leather-like fabrics, or fabrics that need fireproof treatment.

Inicialmente presentado en tela Techno 3D, este modelo es actualmente realizable en varias pieles y telas.

Sin embargo, como las pieles y las telas no son extensibles, es necesario añadir unas costuras en la parte interior del respaldo para garantizar un mejor acabado.

IMPORTANTE: esta limitación técnica no permite el uso de las pieles de un grosor superior o igual a 1,6 mm, de telas con motivos o rayadas (con racords), de terciopelos, microfibras, telas gruesas, telas y pieles rígidas, falsas pieles y de telas que necesiten un tratamiento ignífugo.

EDITO CANAPE / SOFA

design Sacha LAKIC

20 Canapé 1.5 place
1.5-seat sofa
Sofá 1.5 plaza

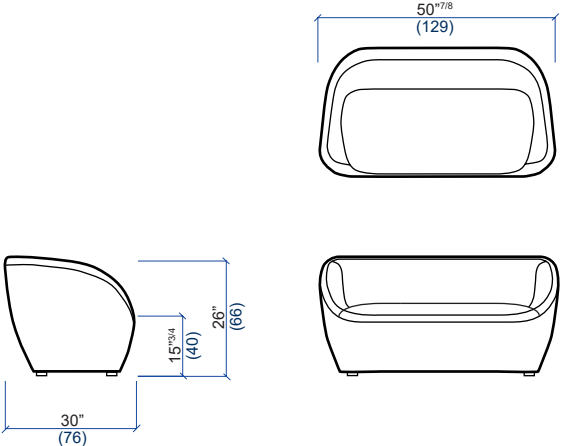

30 Canapé 2 places
2-seat sofa
Sofá 2 plazas

