

# INTEMPOREL

design Maurizio MANZONI

rochebobois  
PARIS



# INTEMPOREL

design Maurizio MANZONI

**rochebobo**is  
PARIS



# INTEMPOREL

design Maurizio MANZONI

rochebobois  
PARIS

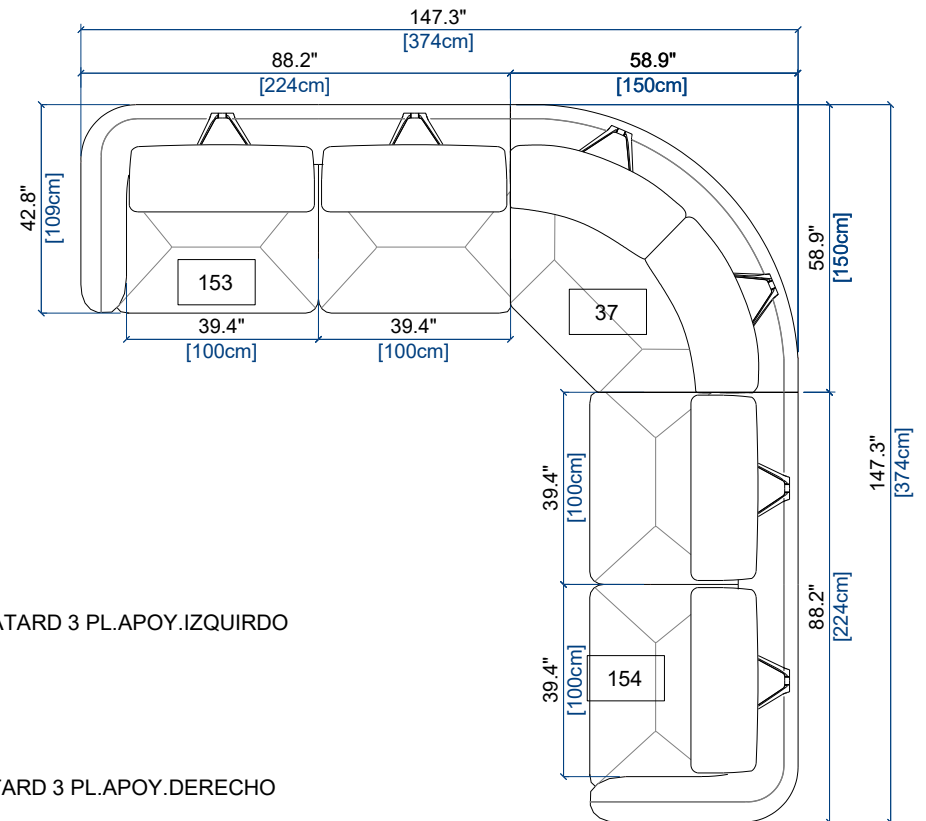

153 GRAND BATARD 3 PL.ACC.GAUCHE / LARGE 3-SEAT 1-ARM UNIT LEFT ARMREST / GRAN BATARD 3 PL.APOY.IZQUIRDO

37 GRAND ANGLE ROND / LARGE ROUND CORNER / GRAN ANGULO REDONDO

154 GRAND BATARD 3 PL.ACC.DROIT / LARGE 3-SEAT 1-ARM UNIT RIGHT ARMREST / GRAN BATARD 3 PL.APOY.DERECHO

# INTEMPOREL

design Maurizio MANZONI

rochebobois  
PARIS



## INFORMATIONS TECHNIQUES / TECHNICAL SPECIFICATIONS / FICHA TECNICA :

Structure bois FSC : Sapin massif, multiplis de pin (CARB)

Structure dossiers relevables : Fonte d'aluminium laqué

Structure assise : Mécanique avec sangles

Suspension : Sangles élastiques entrecroisées Extra Large Haute Résilience

Garnissage assise : Mousse polyuréthane bi-densité 35-40 kg/m<sup>3</sup>

Garnissage dossier : Mousse polyuréthane densité 21 kg/m<sup>3</sup> et flocons de microfibras polyester

Coussins déco : Plumes et fibres (50% plumes d'oie et canard et 50% fibres de polyester)

Pétement : Sapin massif et multiplis de pin gainé de tissu ou cuir

FSC wood structure: Solid fir wood, pine plywood (CARB)

Structure of adjustable backs: Lacquered cast aluminum

Structure of seat cushion: mechanism with straps

Suspension: Extra Wide High Resilience cross Elastic Straps

Seat cushion: Bi-density polyurethane foam 35-40 kg/m<sup>3</sup>

Back cushion: Polyurethane foam density 21 kg/m<sup>3</sup> and polyester microfibers flakes

Deco cushions: Feathers and fibers (50% goose and duck feathers and 50% polyester fibers)

Base: Solid fir wood and pine plywood covered in fabric or leather

Estructura de madera FSC: Abeto macizo, multilaminado de pino (CARB)

Estructura de respaldos elevables: Fundición de aluminio lacado

Estructura de asiento: Mecanismo con cinchas

Suspensión: Cinchas elásticas entrecruzadas de Alta Resiliencia

Relleno asiento: Espuma de poliuretano bi-densidad 35-40 kg/m<sup>3</sup>

Relleno respaldo: Espuma de poliuretano densidad 21 kg/m<sup>3</sup> y copos de microfibras poliéster

Cojín pequeño: Plumas y fibras (50% plumas de oca y pato y 50% fibras poliéster)

Patatas: Abeto macizo y multilaminado de pino revestido en tela o piel

## OBSERVATIONS / OBSERVATIONS / OBSERVACIONES :

- Fabrication Européenne
- Le service "sur mesure" est disponible sur demande préalable de faisabilité
- Modèle réalisable dans l'ensemble des revêtements de la collection ROCHE BOBOIS à l'exception des velours, des tissus à poils, des tissus Câlin et Moorea et des tissus matelassés Ondea, Dune, Equateur et Méridien.
- Réalisable en cuir avec des coutures supplémentaires (voir page 6)
- Dossiers relevables avec mécaniques manuelles
- «Assise coulissante» à mécanismes électriques indépendants, avec Touch Button dissimulé sur le côté de l'assise
- Made in Europe
- Customization is available upon request and subject to feasibility
- Model available in all exclusive materials from the ROCHE BOBOIS collection with the exception of velvets, pile fabrics, Câlin and Moorea fabrics and Ondea, Dune, Equateur and Méridien quilted fabrics.
- Available in leather with additional stitching (see page 6)
- Adjustable back with manual mechanism
- "Sliding seat cushion" with electric independent mechanism with Touch Button concealed on the side of the seat cushion
- Fabricación europea
- El servicio de personalización está disponible bajo petición y sujeto a viabilidad
- Modelo realizable en todos los revestimientos de la colección ROCHE BOBOIS excepción de los terciopelos, las telas de pelo, las telas Câlin y Moorea y las telas acolchadas Ondea, Dune, Equateur y Méridien.
- Realizable en cuero con costuras adicionales (ver página 6)
- Respaldos elevables con mecanismo manual
- "Asiento deslizable" con mecanismo eléctrico independiente con Touch Button escondido en el lateral del cojín del asiento

## OPTIONS / OPTIONAL / OPCIONES :

- Structure dossiers relevables disponibles dans plusieurs finitions : aluminium laqué Nickel noir, Blanc mat (RAL 9010) ou Noir mat (voir page 5)
- Prise secteur adaptée à chaque pays
- Ce modèle existe en version "assise fixe", "assise mixtes" et "assises coulissante"
- Confort normal ou ferme
- Coussin déco carré
- Adjustable back available in the following finishes: lacquered aluminum Black Nickel, matte White (RAL 9010) or matte Black (see page 5)
- Outlet available for every country
- This model is available in "fixed seat cushion", "mixed seat cushion" and "sliding seat cushion" versions.
- Standard or firm comfort
- Square deco cushion
- Estructura de los respaldos elevables disponible en varios acabados: aluminio lacado Níquel negro, Blanco mate (RAL 9010) o Negro mate (ver página 5)
- Enchufe adaptado a cada país
- Este modelo está disponible en versiones "asiento fijo", "asiento mixto" y "asiento deslizable"
- Confort normal o firme
- Cojín deco cuadrado



La structure de ce canapé est certifiée FSC™ mixte. Elle est composée de matériaux provenant de forêts certifiées FSC™ gérées de façon responsable et d'autres sources contrôlées.

This sofa's structure has FSC™ Mix certification. It is made with a mixture of materials from responsibly managed, FSC™-certified forests and from other controlled sources.

La estructura de este sillón está certificada FSC™ mixto. Esta compuesta de materiales provenientes de bosques certificados FSC™ gestionados responsablemente y de otras fuentes controladas.

## FINITIONS MÉCANISME DOSSIER / ADJUSTABLE BACK FINISH ACABADO RESPALDOS ELEVABLES



Laqué Nickel Noir  
Black Nickel laquer  
Lacado Níquel Negro



Laqué Blanc mat (RAL 9010)  
Matte White laquer (RAL 9010)  
Lacado Blanco mate (RAL 9010)



Laqué Noir matte  
Matte Black Laquer  
Lacado Negro mate

# INTEMPOREL

design Maurizio MANZONI

rochebobois  
PARIS

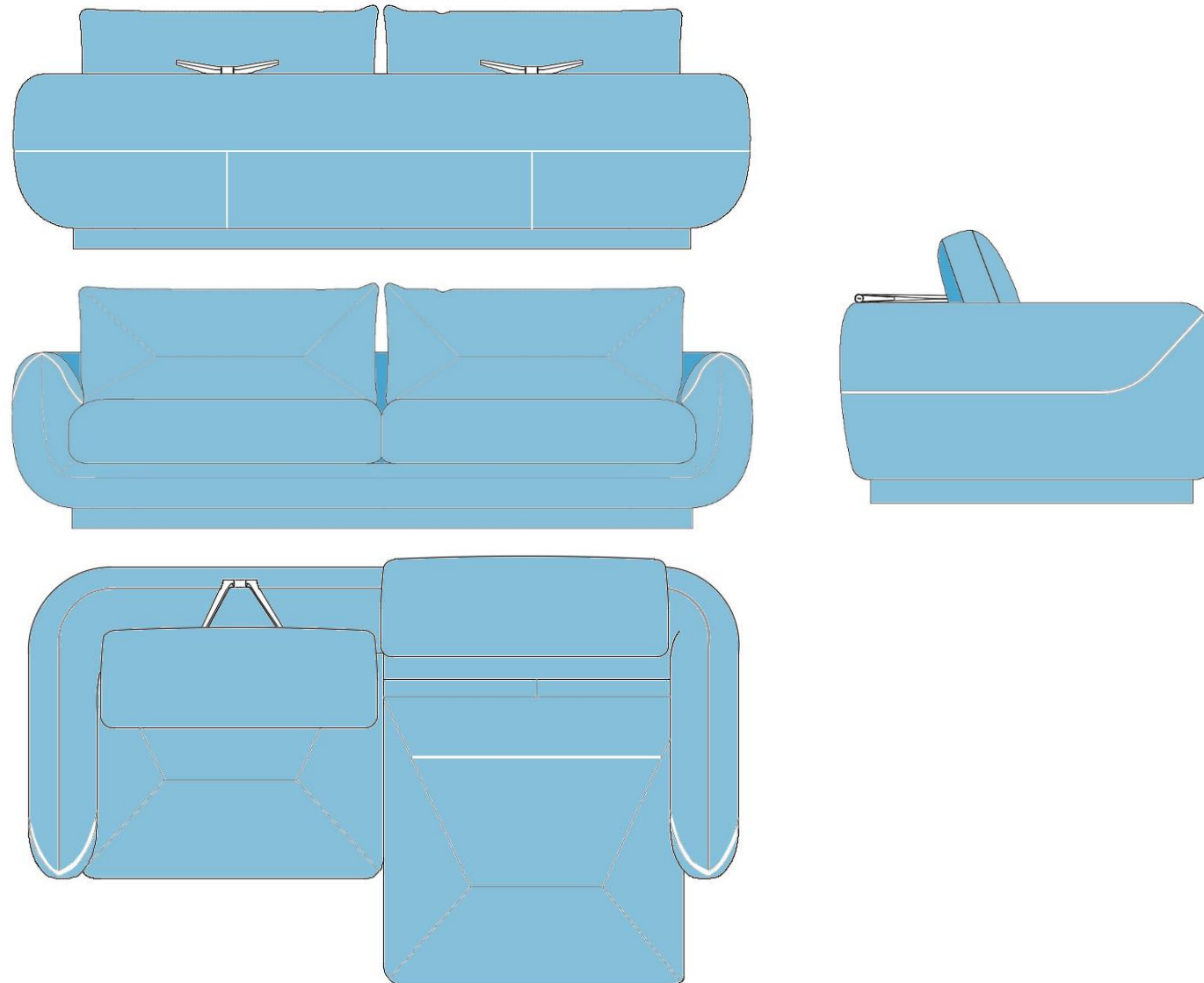

Ce modèle est réalisable dans une multitude de revêtements, en cuir et en tissu.

Cependant, lorsque ce modèle est habillé de cuir, il est indispensable de rajouter des coutures supplémentaires sur l'assise coulissante, à l'avant et sur les côtés des accoudoirs et à l'arrière du dos, afin d'assurer une meilleure finition.

This model is available in both leather and fabric.

However, when the sofa is upholstered in leather, additional stitching has to be added on the sliding seat, to the front and to the sides of the armrests and to the back of the back cushion, to ensure a better finish.

Este modelo se puede realizar en múltiples revestimientos, en piel y tela

Sin embargo, cuando este modelo está tapizado en cuero, es indispensable añadir costuras suplementaria en el asiento deslizante, en la parte delantera y en los lados de los reposabrazos, y en la parte posterior del cojin del respaldo, para asegurar un mejor acabado.

# INTEMPOREL

design Maurizio MANZONI

rochebobois  
PARIS

- \* CANAPE 3/4 PLACES  
3/4-SEAT SOFA  
SOFA 3-4 PLAZAS

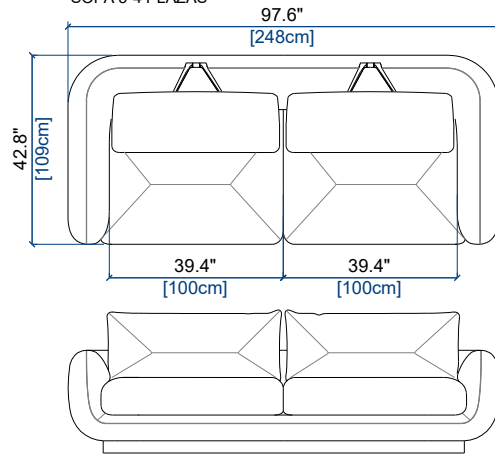

height: 31.5"/39.8" [80/101 cm]  
seat height: 17" [43 cm]  
arm height: 9.4" [24 cm]

- \* GRAND CANAPE 3 PLACES  
LARGE 3-SEAT SOFA  
GRAN SOFA 3 PLAZAS

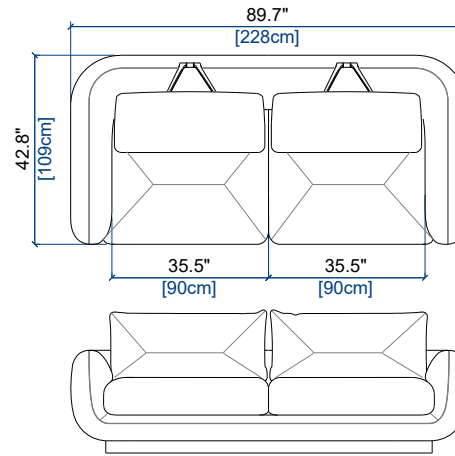

height: 31.5"/39.8" [80/101 cm]  
seat height: 17" [43 cm]  
arm height: 9.4" [24 cm]

- \* CANAPE 3 PLACES  
3-SEAT SOFA  
SOFA 3 PLAZAS

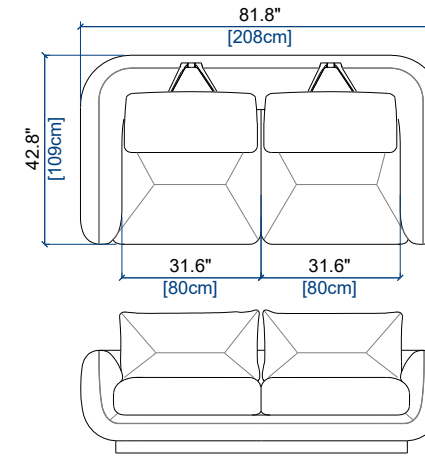

height: 31.5"/39.8" [80/101 cm]  
seat height: 17" [43 cm]  
arm height: 9.4" [24 cm]

- \* CANAPE 2,5 PLACES  
2.5-SEAT SOFA  
SOFA 2,5 PLAZAS

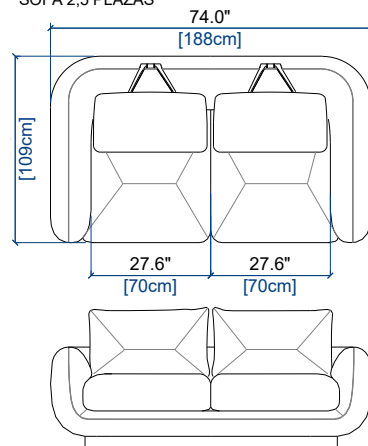

height: 31.5"/39.8" [80/101 cm]  
seat height: 17" [43 cm]  
arm height: 9.4" [24 cm]

- \* CANAPE 2 PLACES  
2-SEAT SOFA  
SOFA 2 PLAZAS

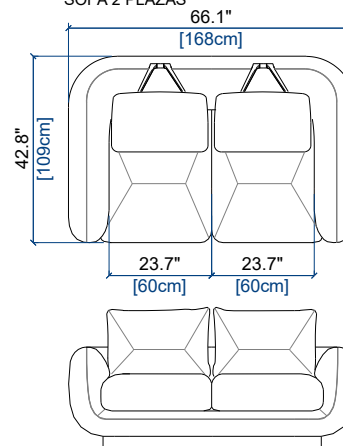

height: 31.5"/39.8" [80/101 cm]  
seat height: 17" [43 cm]  
arm height: 9.4" [24 cm]

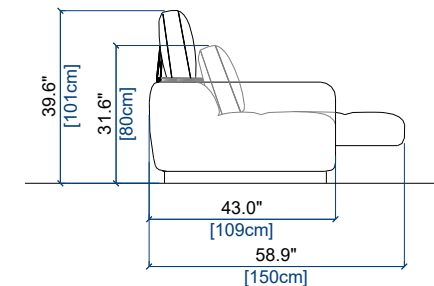
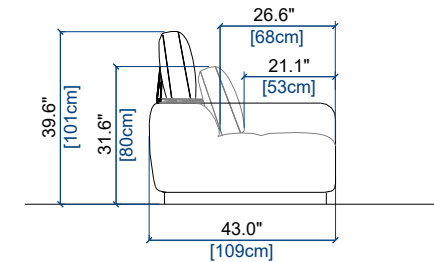

\* Possibilité de choisir des assises mixtes (une fixe et une coulissante) / Possibility to choose mixed seats (one fixed and one sliding) / Posibilidad de elegir asientos mixtas (uno fijo y otro corredizo)

# INTEMPOREL

design Maurizio MANZONI

rochebobois  
PARIS

GRAND FAUTEUIL  
LARGE ARMCHAIR  
GRAN SILLÓN

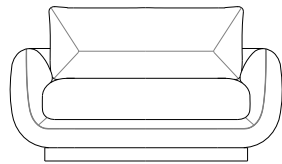
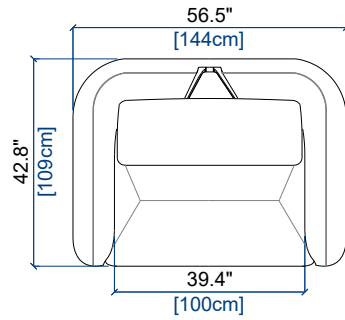

height: 31.5"/39.8" [80/101 cm]  
seat height: 17" [43 cm]  
arm height: 9.4" [24 cm]

FAUTEUIL  
ARMCHAIR  
SILLÓN

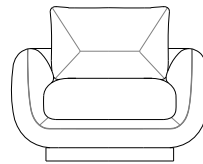
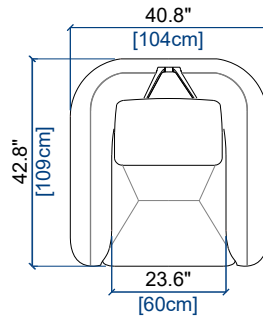

height: 31.5"/39.8" [80/101 cm]  
seat height: 17" [43 cm]  
arm height: 9.4" [24 cm]

POUF RECTANGULAIRE  
RECTANGULAR OTTOMAN  
PUF RECTANGULAR

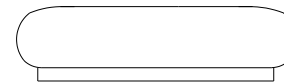
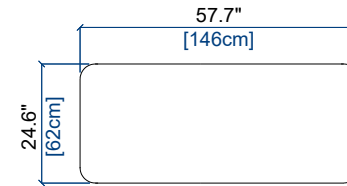

seat height: 15.4" [39 cm]

PETIT COUSSIN  
SMALL CUSHION  
COJIN PEQUEÑO

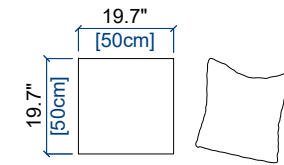

# INTEMPOREL

design Maurizio MANZONI

rochebobois  
PARIS

\* 153 GRAND BATARD 3 PL.ACC.GAUCHE  
LARGE 3-SEAT 1-ARM UNIT LEFT ARMREST  
GRAN BATARD 3 PL.APOY.IZQUIRDO

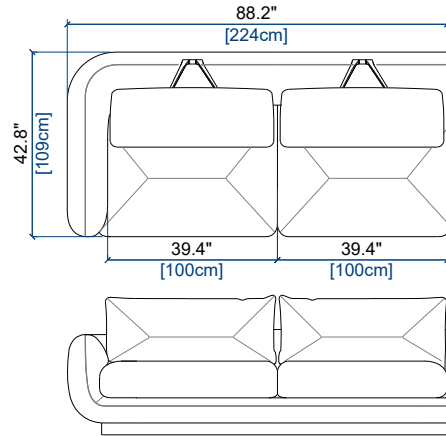

height: 31.5"/39.8" [80/101 cm]  
seat height: 17" [43 cm]  
arm height: 9.4" [24 cm]

\* 154 GRAND BATARD 3 PL.ACC.DROIT  
LARGE 3-SEAT 1-ARM UNIT RIGHT ARMREST  
GRAN BATARD 3 PL.APOY.DERECHO

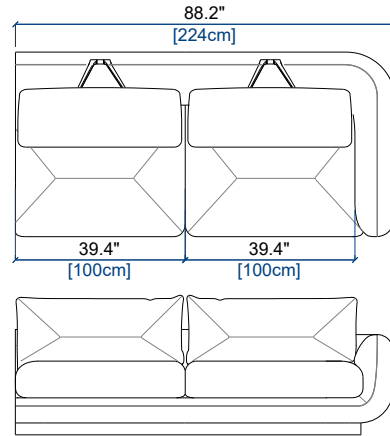

height: 31.5"/39.8" [80/101 cm]  
seat height: 17" [43 cm]  
arm height: 9.4" [24 cm]

\* 105 BATARD 3 PL.ACC.GAUCHE  
3-SEAT 1-ARM UNIT LEFT ARMREST  
BATARD 3 PL.APOY.IZQUIRDO

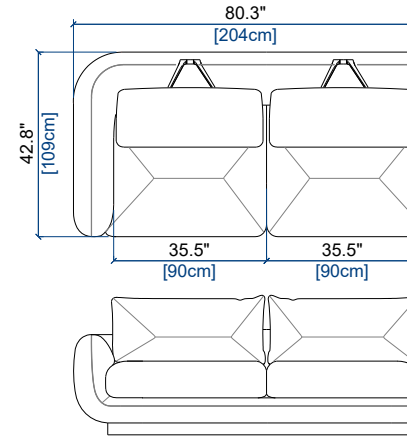

height: 31.5"/39.8" [80/101 cm]  
seat height: 17" [43 cm]  
arm height: 9.4" [24 cm]

\* 106 BATARD 3 PL.ACC.DROIT  
3-SEAT 1-ARM UNIT RIGHT ARMREST  
BATARD 3 PL.APOY.DERECHO

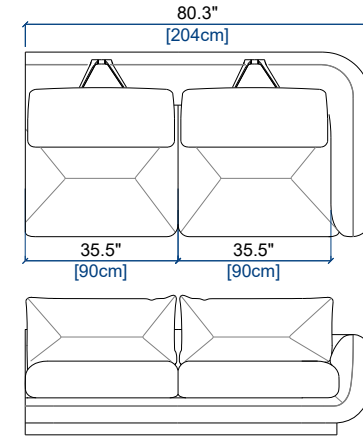

height: 31.5"/39.8" [80/101 cm]  
seat height: 17" [43 cm]  
arm height: 9.4" [24 cm]

\* 63 BATARD 2,5 PL.ACC.GAUCHE  
2.5-SEAT 1-ARM UNIT LEFT ARMREST  
BATARD 2,5 PL.APOY.IZQUIRDO

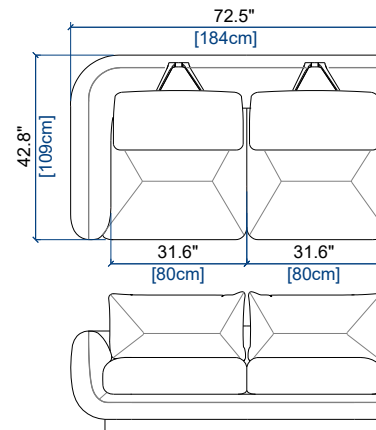

height: 31.5"/39.8" [80/101 cm]  
seat height: 17" [43 cm]  
arm height: 9.4" [24 cm]

\* 62 BATARD 2,5 PL.ACC.DROIT  
2.5-SEAT 1-ARM UNIT RIGHT ARMREST  
BATARD 2,5 PL.APOY.DERECHO

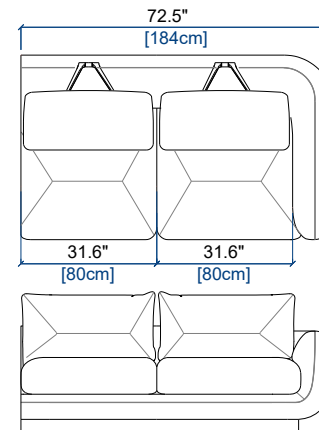

height: 31.5"/39.8" [80/101 cm]  
seat height: 17" [43 cm]  
arm height: 9.4" [24 cm]

\* Possibilité de choisir des assises mixtes (une fixe et une coulissante) / Possibility to choose mixed seats (one fixed and one sliding) / Posibilidad de elegir asientos mixtas (uno fijo y otro corredizo)

\* **27** BATARD 2 PL.ACC.GAUCHE  
2-SEAT 1-ARM UNIT LEFT ARMREST  
BATARD 2 PL.APOY.IZQUIRDO

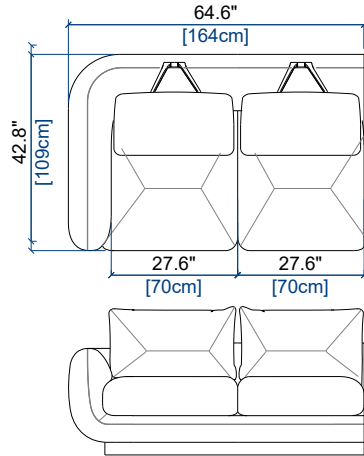

height: 31.5"/39.8" [80/101 cm]  
seat height: 17" [43 cm]  
arm height: 9.4" [24 cm]

\* **26** BATARD 2 PL.ACC.DROIT  
2-SEAT 1-ARM UNIT RIGHT ARMREST  
BATARD 2 PL.APOY.DERECHO

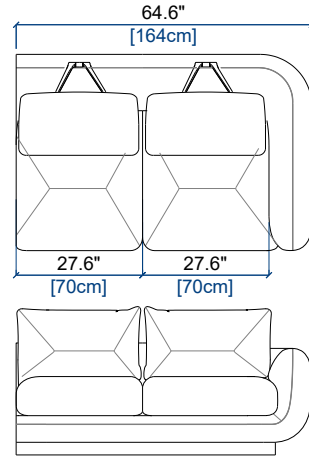

height: 31.5"/39.8" [80/101 cm]  
seat height: 17" [43 cm]  
arm height: 9.4" [24 cm]

**151** BATARD 1,5 PL.ACC.GAUCHE  
1.5-SEAT 1-ARM UNIT LEFT ARMREST  
BATARD 1,5 PL.APOY.IZQUIRDO

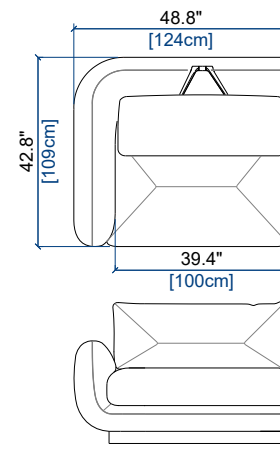

height: 31.5"/39.8" [80/101 cm]  
seat height: 17" [43 cm]  
arm height: 9.4" [24 cm]

**152** BATARD 1,5 PL.ACC.DROIT  
1.5-SEAT 1-ARM UNIT RIGHT ARMREST  
BATARD 1,5 PL.APOY.DERECHO

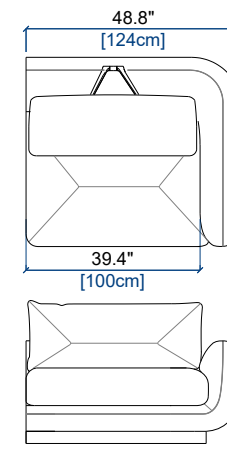

height: 31.5"/39.8" [80/101 cm]  
seat height: 17" [43 cm]  
arm height: 9.4" [24 cm]

**37** GRAND ANGLE PANORAMIQUE  
LARGE PANORAMIC CORNER  
GRAN ANGULO PANORAMICO

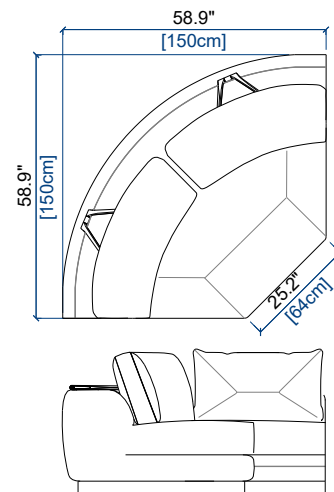

height: 31.5"/39.8" [80/101 cm]  
seat height: 17" [43 cm]

**01** CHAUFFEUSE  
ARMLESS CHAIR  
CHAUFFEUSE

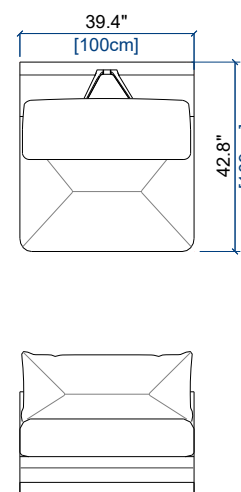

height: 31.5"/39.8" [80/101 cm]  
seat height: 17" [43 cm]

\* Possibilité de choisir des assises mixtes (une fixe et une coulissante) / Possibility to choose mixed seats (one fixed and one sliding) / Posibilidad de elegir asientos mixtas (uno fijo y otro corredizo)

# INTEMPOREL

design Maurizio MANZONI

**rochebobois**  
PARIS

08

GRAND ANGLE/MERIDIENNE GAUCHE  
LARGE CORNER/MERIDIENNE LEFT  
GRAN ANGULO/MERIDIENNE IZQUIERDA

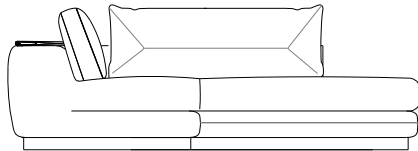
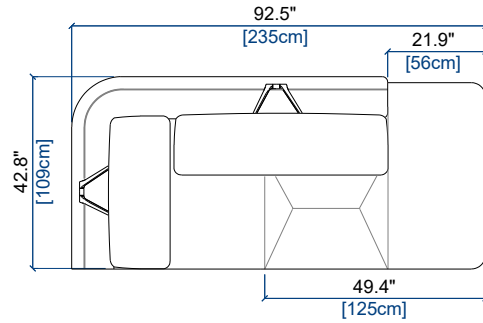

height: 31.5"/39.8" [80/101 cm]  
seat height: 17" [43 cm]

09

GRAND ANGLE/MERIDIENNE DROITE  
LARGE CORNER/MERIDIENNE RIGHT  
GRAN ANGULO/MERIDIENNE DERECHA

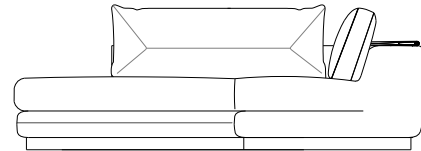
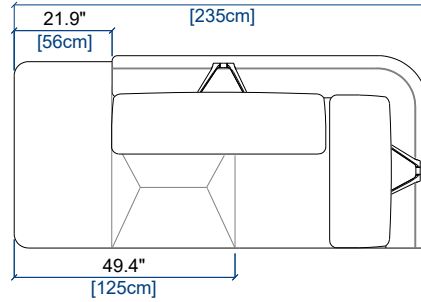

height: 31.5"/39.8" [80/101 cm]  
seat height: 17" [43 cm]

8P

ANGLE/MERIDIENNE GAUCHE  
CORNER/MERIDIENNE LEFT  
ANGULO/MERIDIENNE IZQUIERDA

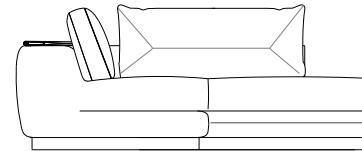
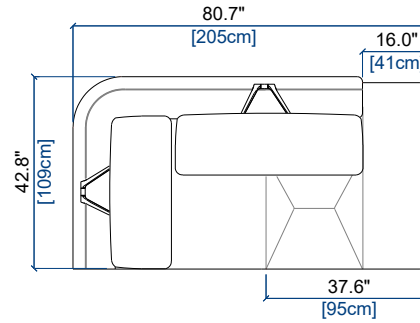

height: 31.5"/39.8" [80/101 cm]  
seat height: 17" [43 cm]

9P

ANGLE/MERIDIENNE DROITE  
CORNER/MERIDIENNE RIGHT  
ANGULO/MERIDIENNE DERECHA

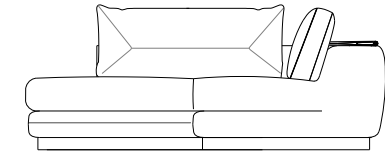
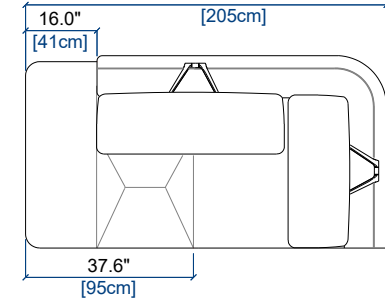

height: 31.5"/39.8" [80/101 cm]  
seat height: 17" [43 cm]

10P

PETIT TERMINAL GAUCHE  
SMALL END UNIT LEFT  
PEQUEÑA TERMINAL IZQUIERDA

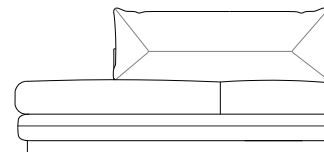
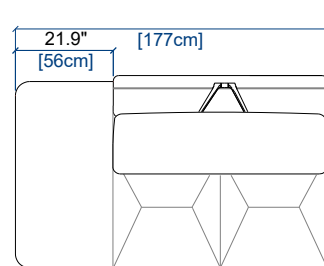

height: 31.5"/39.8" [80/101 cm]  
seat height: 17" [43 cm]

11P

PETIT TERMINAL DROIT  
SMALL END UNIT RIGHT  
PEQUEÑA TERMINAL DERECHA

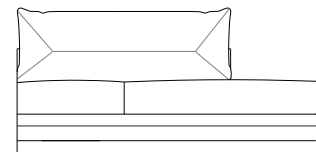
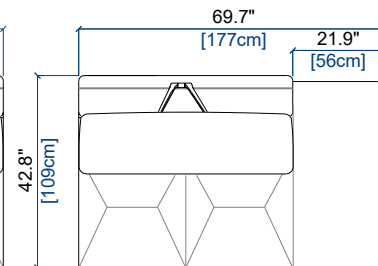

height: 31.5"/39.8" [80/101 cm]  
seat height: 17" [43 cm]