

# HUBBA

design Andrii Kovalskyi

**rochebobois**  
PARIS



## **INFORMATIONS TECHNIQUES / TECHNICAL SPECIFICATIONS / CARACTERISTICAS TECNICAS:**

Structure : Métal

Assise : Mousse polyuréthane multi-densité OSF25 + OSF35 + 30C kg/m<sup>3</sup> et résine 200 gr

Dossier : Mousse polyuréthane multi-densité 21M + OSF35 + 40PH kg/m<sup>3</sup> et résine 200 gr

Piètement invisible

Structure: Metal

Seat : Multi-density polyurethane foam OSF25 + OSF35 + 30C kg/m<sup>3</sup> and resin 200 gr

Back: Multi-density polyurethane foam 21M + OSF35 + 40PH kg/m<sup>3</sup> and resin 200 gr

Invisible base

Estructura: Metal

Asiento: Espuma de poliuretano multidensidad OSF25 + OSF35 + 30C kg/m<sup>3</sup> y resina 200g

Respaldo: Espuma de poliuretano multidensidad 21M + OSF35 + 40PH kg/m<sup>3</sup> y resina 200g

Patas invisibles

## **OBSERVATIONS / OBSERVATIONS / OBSERVACIONES:**

- Fabrication Européenne
- Modèle réalisable uniquement dans les tissus extensibles de la collection Roche Bobois : Bamboo, Chroma, Orsetto Flex, Passion, Pixel et Smile Flex
- Made in Europe
- Model only available in the stretch fabrics of Roche Bobois collection: Bamboo, Chroma, Orsetto Flex, Passion, Pixel and Smile Flex
- Fabricación europea
- Modelo realizable únicamente en las telas elásticas de la colección Roche Bobois: Bamboo, Chroma, Orsetto Flex, Passion, Pixel y Smile Flex

# HUBBA

design Andrii Kovalskyi

rochebobois  
PARIS

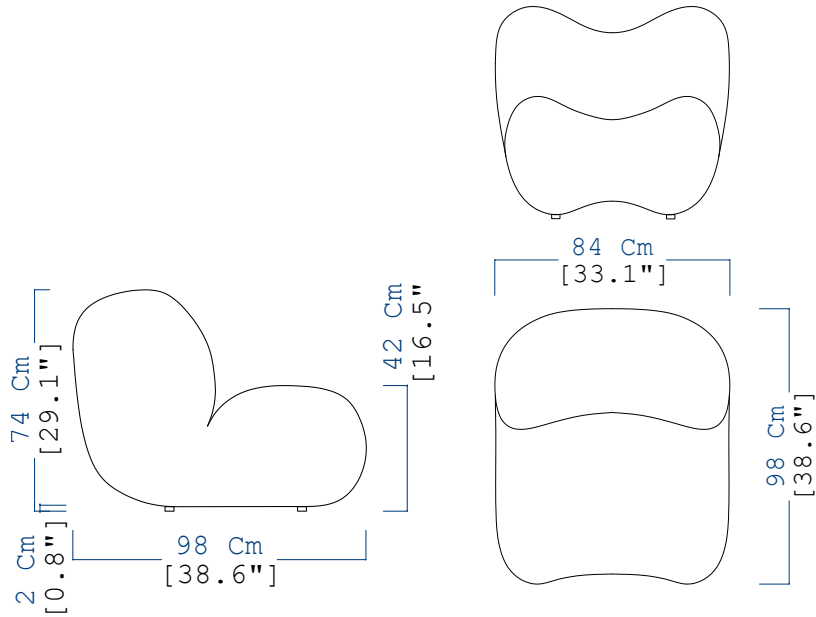

**HU01**  
FAUTEUIL  
ARMCHAIR  
SILLON

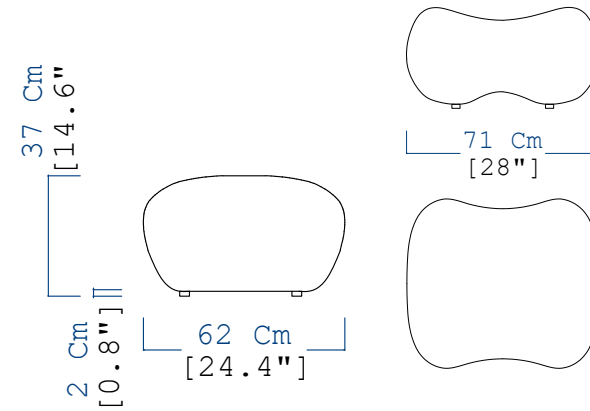

**HU02**  
POUF  
OTTOMAN  
PUF