

A-PROPOS - DOSSIERS MOBILES

design Maurizio MANZONI

rochebobo
PARIS



A-PROPOS - DOSSIERS MOBILES

design Maurizio MANZONI

rochebobois
PARIS



A-PROPOS - DOSSIERS MOBILES

design Maurizio MANZONI

rochebobois
PARIS

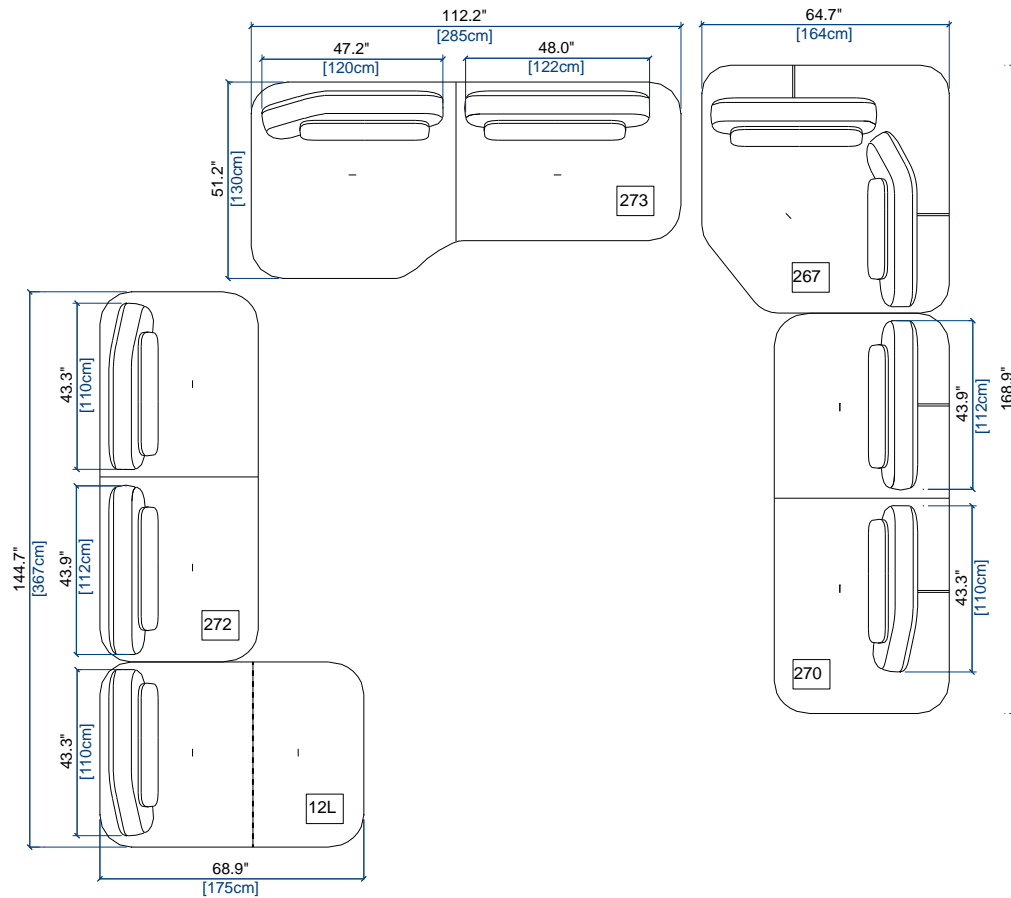

- 12L** CHAISE LONGUE GAUCHE / LOUNGE CHAIR LEFT / CHAISE LONGUE IQDA
- 272** BANQUETTE 3/4 PL.DROITE / 3-4 SEAT ARMLESS UNIT RIGHT / BANQUETA 3/4 PL.DCHA
- 273** MAXI BANQUETTE DOUBLE PROF.GAUCHE / MAXI ARMLESS UNIT DOUBLE DEPHT LEFT / MAXI BANQUETA DOBLE PROF.IZQDA
- 267** GRAND ANGLE CARRE GAUCHE / LARGE SQUARE CORNER LEFT / GRAN ÁNGULO CUADRADO IZQDA
- 270** BANQUETTE TERMINAL DROITE / ARMLESS END UNIT RIGHT / BANQUETA TERMINAL DCHA

A-PROPOS - DOSSIERS MOBILES

design Maurizio MANZONI

rochebobois
PARIS



INFORMATIONS TECHNIQUES / TECHNICAL SPECIFICATIONS / FICHA TECNICA :

Structure bois FSC : Sapin massif, multiplis de pin, panneaux de particules (CARB)
Suspension : Sangles élastiques Extra Grandes Haute Résilience
Garnissage assise monobloc : Mousse polyuréthane bi-densité 35-25 kg/m³
Garnissage dossier monobloc : Mousse polyuréthane bi-densité 21-42 kg/m³
Garnissage coussin cale-reins : Flocons de fibres polyester
Garnissage accoudoir : 100% plumes d'oie et canard
Socle : Tilleul massif teinté Noir
Piètement : Hêtre massif teinté Noir

FSC wood structure: Solid fir wood, pine plywood, engineered composite wood (CARB)
Suspension: Extra Wide High Resilience Elastic Straps
Monobloc seat cushion: Bi-density polyurethane foam 35-25 kg/m³
Monobloc back cushion: Bi-density polyurethane foam 21-42 kg/m³
Lumbar cushion: Polyester fibre flakes
Arm cushion: 100% goose and duck feathers
Socle: Solid linden with stained finish col. black
Base: Solid beech with stained finish col. black

Estructura de madera FSC: Abeto macizo, multilaminado de pino, paneles de particulas (CARB)
Suspensión: Cinchas elásticas Extra Anchas de Alta Resiliencia
Interior asiento monobloc: Espuma de poliuretano bi-densidad 35-25 kg/m³
Interior respaldo monobloc: Espuma de poliuretano bi-densidad 21-42 kg/m³
Interior cojines riñoneros: Copos de fibra poliéster
Interior apoyabrazo: 100% pluma de oca y pato
Zócalo: Tilo macizo tintado de negro
Patatas: Haya maciza tintada negro

OBSERVATIONS / OBSERVATIONS / OBSERVACIONES :

- Fabrication Européenne
- Le service « sur-mesure » n'est pas disponible sur ce modèle
- Modèle réalisable dans l'ensemble des revêtements de la collection ROCHE BOBOIS à l'exception du tissu Jersey et des velours
- Dans la version en cuir il est indispensable de rajouter des coutures supplémentaires (voir page 5)
- Mécanisme à balancier intégré dans les dossiers
- Made in Europe
- Not customizable
- Model available in all exclusive materials from the ROCHE BOBOIS collection, with the exception of Jersey fabric and velvets
- In the leather version it is necessary to add some additional stitchings (see page 5)
- Manual mechanism integrated into the backrests
- Fabricación europea
- El servicio "a medida" no es posible en este modelo
- Modelo realizable en todas las telas y pieles de la colección ROCHE BOBOIS excepto en la tela Jersey y en terciopelo
- En la versión piel es indispensable añadir costuras adicionales (ver página 5)
- Mecanismo a balancín integrado en los respaldos

OPTIONS / OPTIONAL / OPCIONES :

- Existe en version « dossiers fixes »
- Confort normal ou ferme
- Coussin d'accoudoir
- Available in a « fixed backrest »
- Standard or firm comfort
- Arm cushion
- Disponible en versión « respaldo fijo »
- Confort normal o firme
- Cojín apoyabrazo

A-PROPOS - DOSSIERS MOBILES

design Maurizio MANZONI

rochebobois
PARIS

POSITIONNEMENT DES COUTURES POUR LE CUIR / POSITIONING OF STITCHING FOR THE LEATHER POSICIONAMIENTO DE COSTURAS PARA PIEL

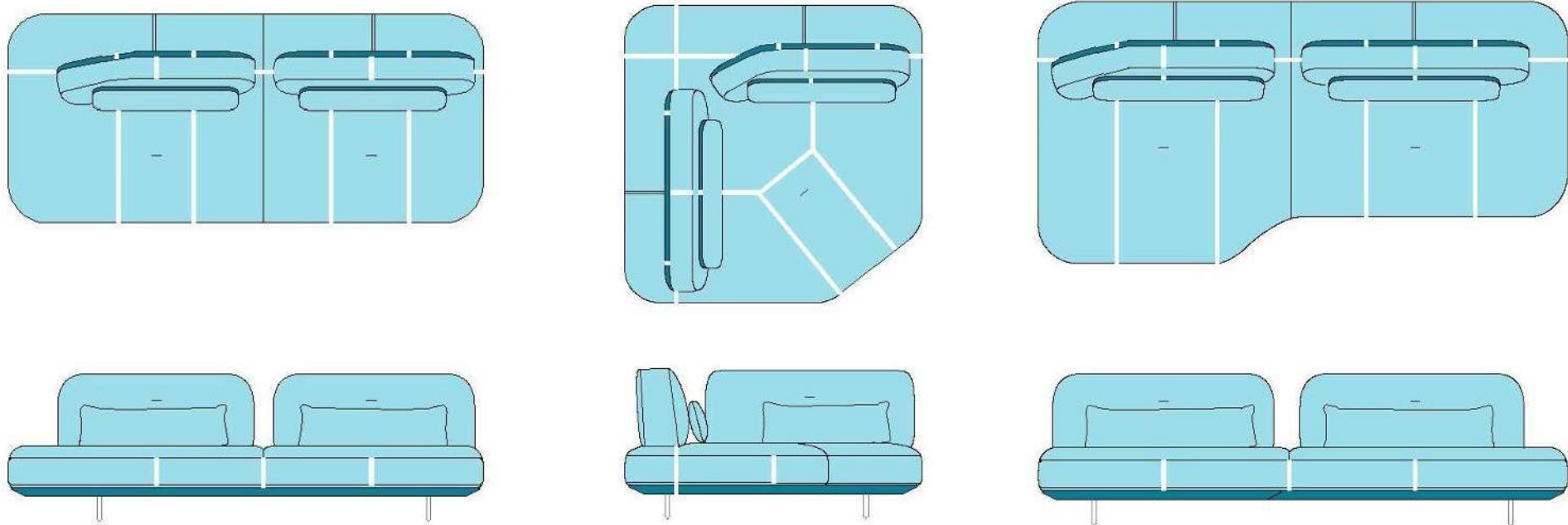

Ce modèle est réalisable dans une multitude de revêtements, en cuir et en tissu.

Cependant, avec les cuirs, il est indispensable de rajouter des coutures supplémentaires au niveau des assises et des dossiers afin d'assurer une meilleure finition.

This model is available in both leather and fabric.

However, with leathers it is essential to add additional stitchings to the seats and backrests cushions to ensure a better finish.

Este modelo se puede realizar en múltiples revestimientos, en piel y tela

Sin embargo, con la piel, es fundamental añadir costuras suplementarias a los asientos y respaldos para asegurar un mejor acabado.

A-PROPOS - DOSSIERS MOBILES

design Maurizio MANZONI

rochebobois
PARIS

269 BANQUETTE TERMINAL GAUCHE
ARMLESS END UNIT LEFT
BANQUETA TERMINAL IZQDA

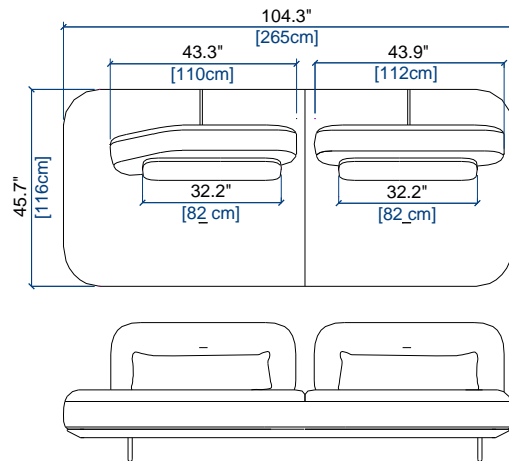

270 BANQUETTE TERMINAL DROITE
ARMLESS END UNIT RIGHT
BANQUETA TERMINAL DCHA

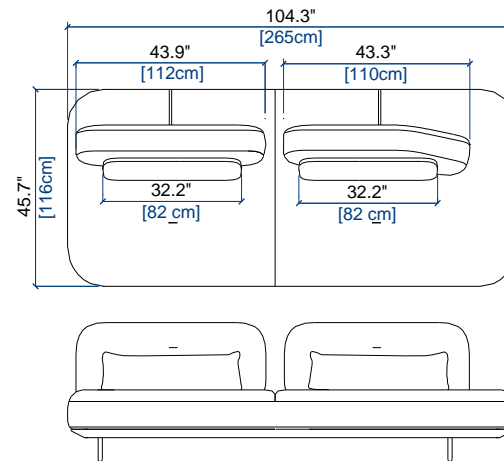

COUSSIN D'ACCOUDOIR
ARM CUSHION
COJÍN APOYABRAZO

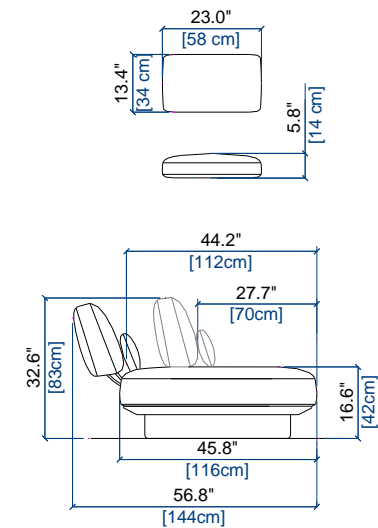

LE SENS DES ÉLÉMENTS EST DÉTERMINÉ PAR LE CÔTÉ DU DOSSIER BISEAUTÉ / THE DIRECTION OF THE ELEMENTS IS DETERMINED BY THE SIDE OF THE BEVELED BACK
LA DIRECCIÓN DE LOS ELEMENTOS ESTÁ DETERMINADA POR EL LADO DEL RESPALDO BISELADO

A-PROPOS - DOSSIERS MOBILES

design Maurizio MANZONI

rochebobois
PARIS

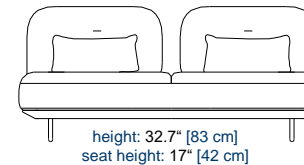
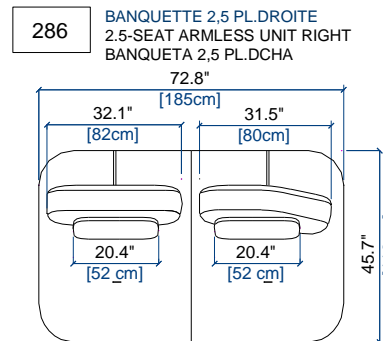
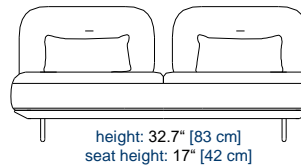
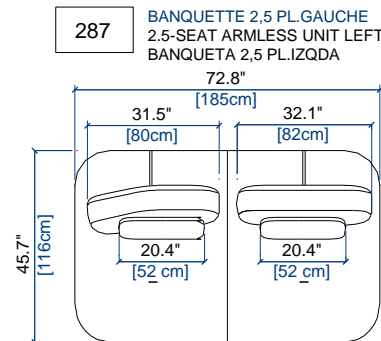
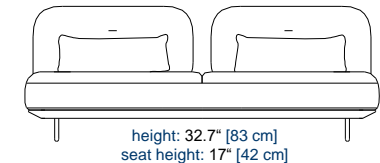
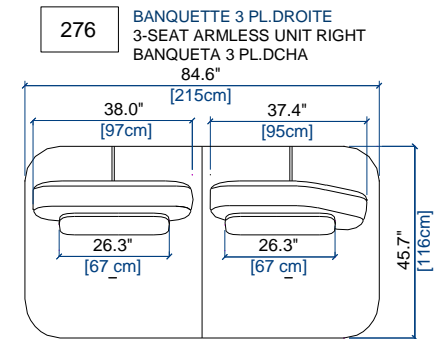
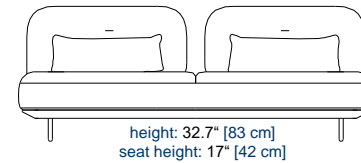
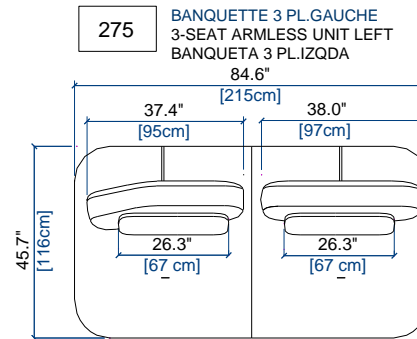
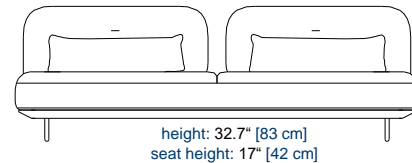
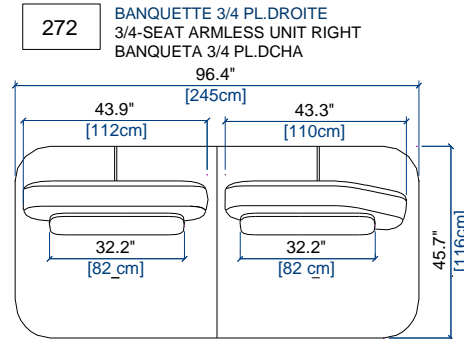
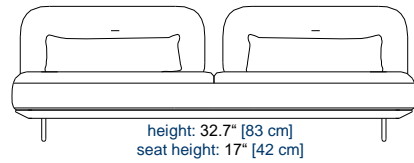
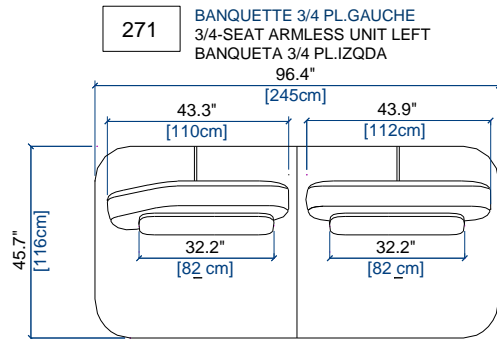

LE SENS DES ÉLÉMENTS EST DÉTERMINÉ PAR LE CÔTÉ DU DOSSIER BISEAUTÉ / THE DIRECTION OF THE ELEMENTS IS DETERMINED BY THE SIDE OF THE BEVELED BACK
LA DIRECCIÓN DE LOS ELEMENTOS ESTÁ DETERMINADA POR EL LADO DEL RESPALDO BISELADO

A-PROPOS - DOSSIERS MOBILES

design Maurizio MANZONI

rochebobois
PARIS

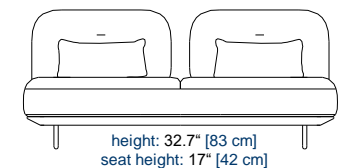
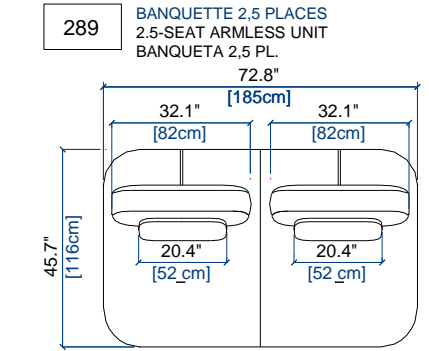
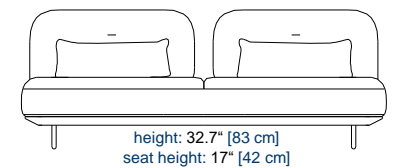
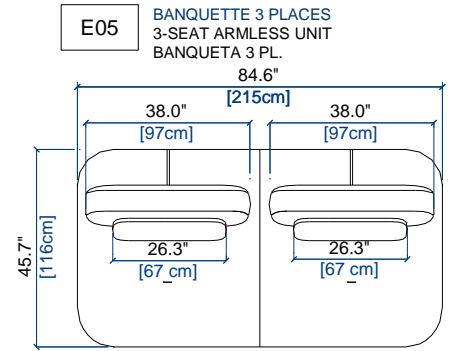
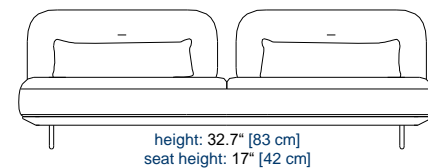
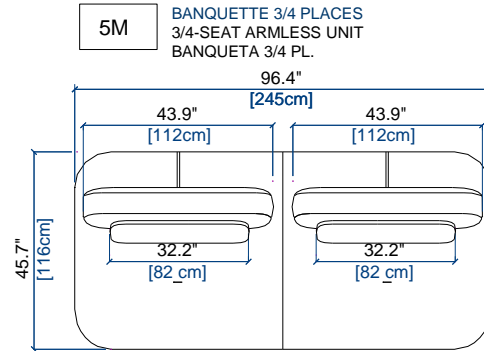
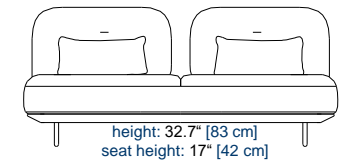
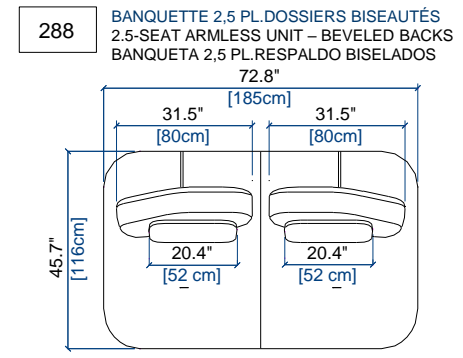
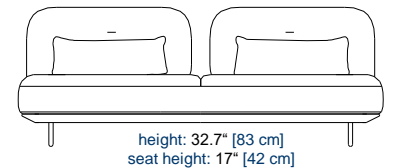
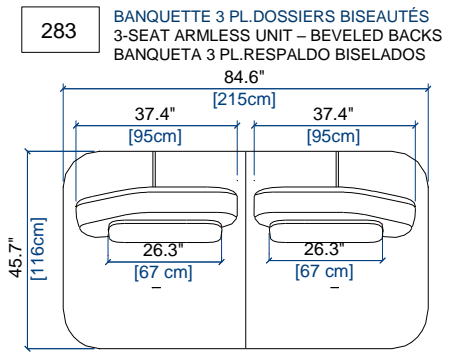
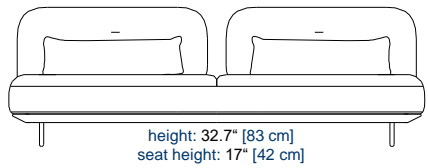
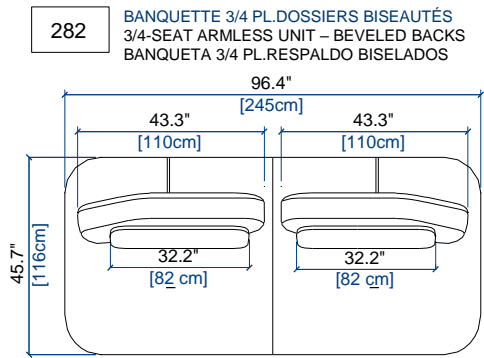

LE SENS DES ÉLÉMENTS EST DÉTERMINÉ PAR LE CÔTÉ DU DOSSIER BISEAUTÉ / THE DIRECTION OF THE ELEMENTS IS DETERMINED BY THE SIDE OF THE BEVELED BACK
LA DIRECCIÓN DE LOS ELEMENTOS ESTÁ DETERMINADA POR EL LADO DEL RESPALDO BISELADO

A-PROPOS - DOSSIERS MOBILES

design Maurizio MANZONI

rochebobois
PARIS

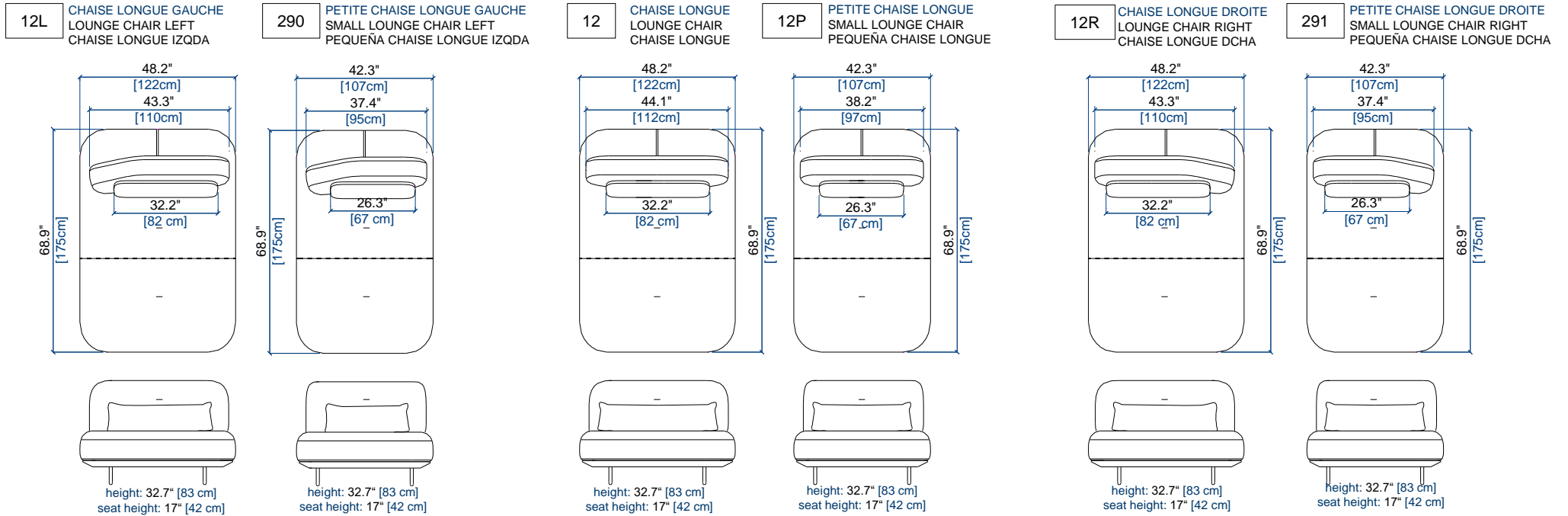

LE SENS DES ÉLÉMENTS EST DÉTERMINÉ PAR LE CÔTÉ DU DOSSIER BISEAUTÉ / THE DIRECTION OF THE ELEMENTS IS DETERMINED BY THE SIDE OF THE BEVELED BACK
LA DIRECCIÓN DE LOS ELEMENTOS ESTÁ DETERMINADA POR EL LADO DEL RESPALDO BISELADO

A-PROPOS - DOSSIERS MOBILES

design Maurizio MANZONI

rochebobois
PARIS

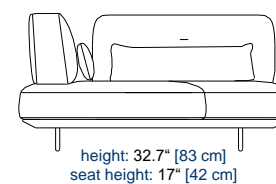
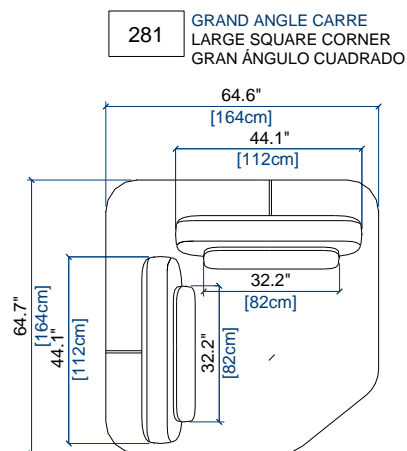
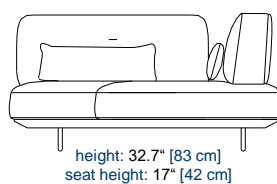
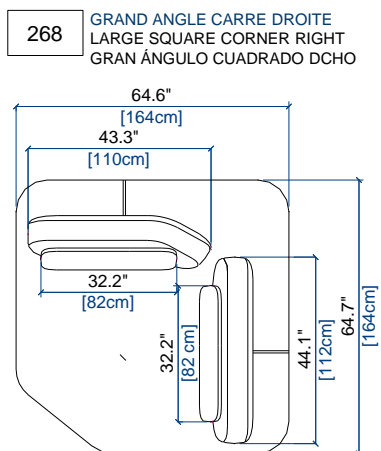
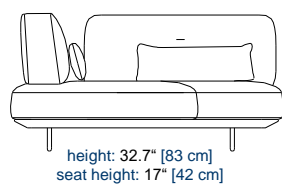
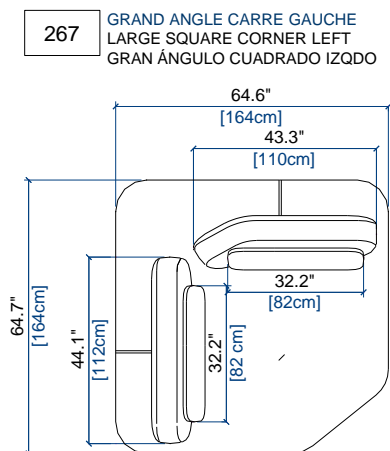

LE SENS DES ÉLÉMENTS EST DÉTERMINÉ PAR LE CÔTÉ DU DOSSIER BISEAUTÉ / THE DIRECTION OF THE ELEMENTS IS DETERMINED BY THE SIDE OF THE BEVELED BACK
LA DIRECCIÓN DE LOS ELEMENTOS ESTÁ DETERMINADA POR EL LADO DEL RESPALDO BISELADO

A-PROPOS - DOSSIERS MOBILES

design Maurizio MANZONI

rochebobois
PARIS

273 MAXI BANQUETTE DOUBLE PROF.GAUCHE
MAXI ARMLESS UNIT DOUBLE DEPHT LEFT
MAXI BANQUETA DOBLE PROF.IZQDA

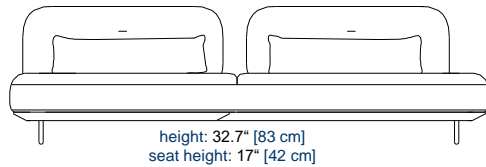
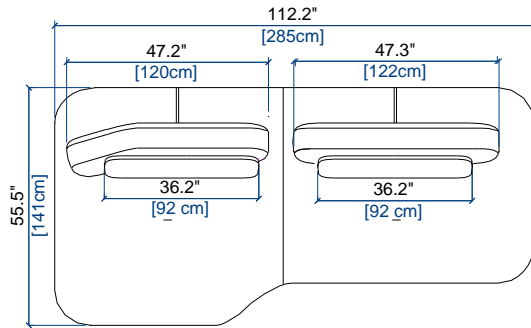

274 MAXI BANQUETTE DOUBLE PROF.DROITE
MAXI ARMLESS UNIT DOUBLE DEPHT RIGHT
MAXI BANQUETA DOBLE PROF.DCHA

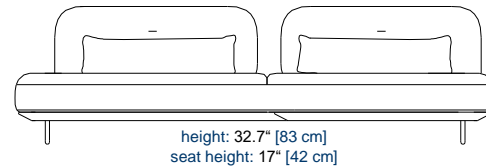
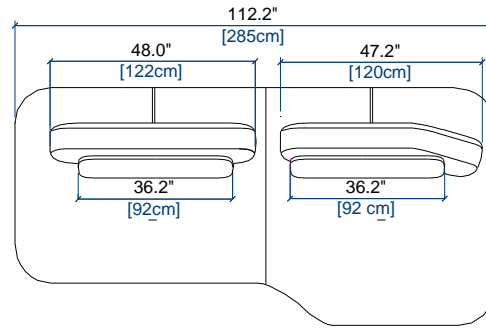

277 GRANDE BANQUETTE DOUBLE PROF.GAUCHE
LARGE ARMLESS UNIT DOUBLE DEPHT LEFT
GRAN BANQUETA DOBLE PROF.IZQDA

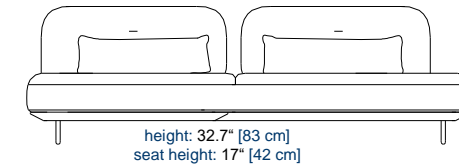
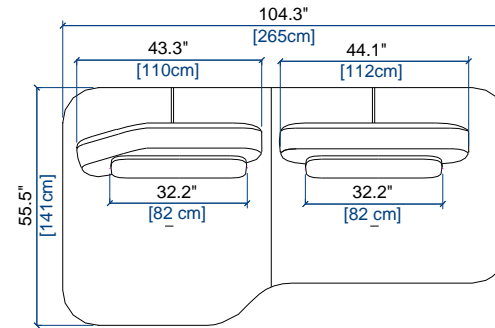

278 GRANDE BANQUETTE DOUBLE PROF.DROITE
LARGE ARMLESS UNIT DOUBLE DEPHT RIGHT
GRAN BANQUETA DOBLE PROF.DCHA

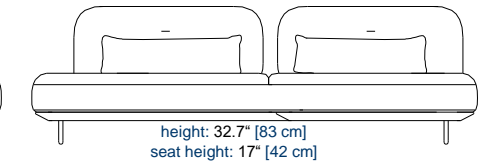
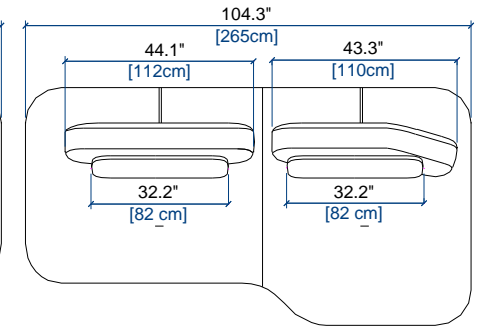

279 MOYEN BANQUETTE DOUBLE PROF.GAUCHE
MEDIUM ARMLESS UNIT DOUBLE DEPHT LEFT
MEDIA BANQUETA DOBLE PROF.IZQDA

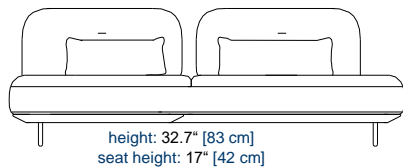
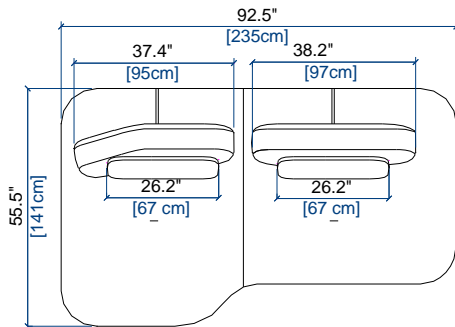

280 MOYEN BANQUETTE DOUBLE PROF. DROITE
MEDIUM ARMLESS UNIT DOUBLE DEPHT RIGHT
MEDIA BANQUETA DOBLE PROF.DCHA

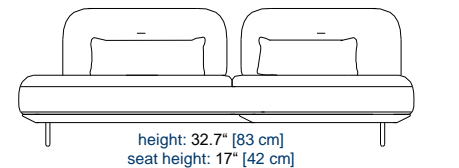
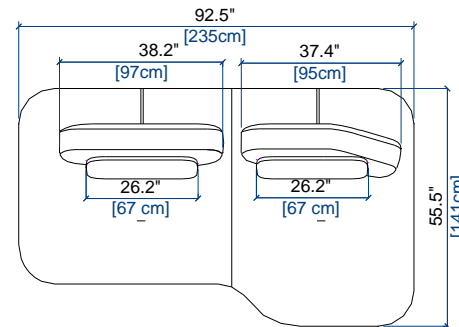

292 PETITE BANQUETTE DOUBLE PROF.GAUCHE
SMALL ARMLESS UNIT DOUBLE DEPHT LEFT
PEQUEÑA BANQUETA DOBLE PROF.IZQDA

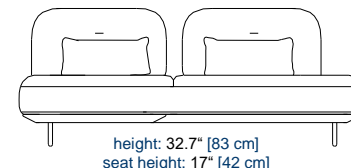
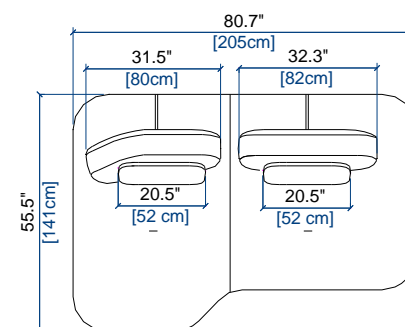

293 PETITE BANQUETTE DOUBLE PROF.DROITE
SMALL ARMLESS UNIT DOUBLE DEPHT RIGHT
PEQUEÑA BANQUETA DOBLE PROF.DCHA

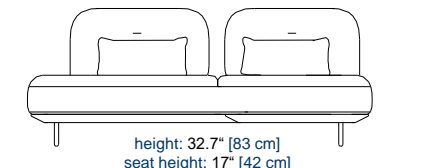
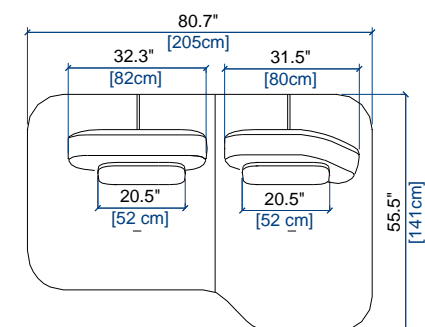

LE SENS DES ÉLÉMENTS EST DÉTERMINÉ PAR LE CÔTÉ DU DOSSIER BISEAUTÉ / THE DIRECTION OF THE ELEMENTS IS DETERMINED BY THE SIDE OF THE BEVELED BACK
LA DIRECCIÓN DE LOS ELEMENTOS ESTÁ DETERMINADA POR EL LADO DEL RESPALDO BISELADO