

Collection PULP

design Eugeni QUITLLET

rochebobois
PARIS



EU584

Collection PULP

design Eugeni QUITLLET

rochebobois
PARIS



Coté sièges, même idée : assise, dossier et accoudoirs semblent issus d'une division cellulaire, comme en un corps en croissance. Et dans cette logique, l'assise est en suspension au-dessus du piétement fuselé aux références scandinaves.

The chairs play on the same idea: seat, back and armrests appear to have formed through cell division, as in a growing body. Building on this theme, the seat seems to float above the tapered, Scandinavian-style leg.

Referente a los asientos, misma idea: asiento, respaldo y apoyabrazos asemejan una división celular, como un cuerpo en crecimiento. Bajo esta lógica, el asiento está en suspensión sobre un pie afilado de referencias escandinavas.



Cette chaise est certifiée FSC™ 100% : le bois provient de forêts certifiées FSC™ gérées responsablement.

This chair is certified FSC™ 100% : the wood comes from FSC™ certified forests responsibly managed.

Esta silla esta certificada FSC™ 100% : la madera proviene de bosques certificados FSC™ gestionados responsablemente.

Collection PULP

design Eugeni QUITLLET

rochebobois
PARIS



Chaise avec structure en hêtre laqué mat ou brillant, coque rembourrée en multiplis avec renforts métallique recouverte de tissu, de cuir ou de tissu aspect cuir.

Chair with structure in beech with glossy or mate lacquer finish, padded shell in plywood with metallic reinforcement upholstered in fabric, leather, or leather-like fabric.

Silla con estructura en haya lacada brillante o mate, carcasa acolchada en multilaminado con refuerzos metálicos revestida de tela, piel o tela aspecto piel.

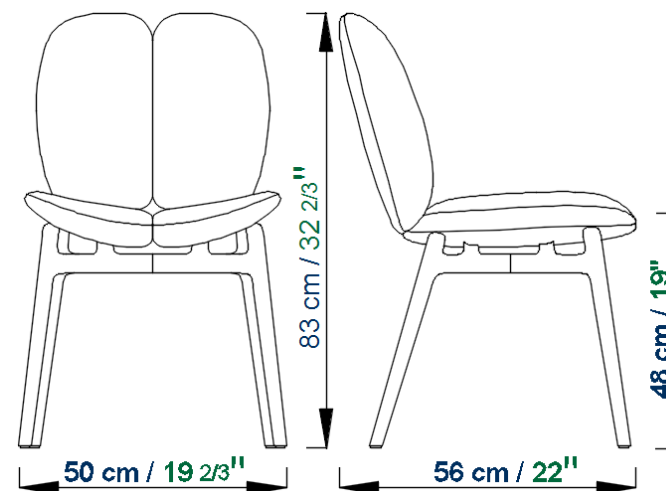

Collection PULP

design Eugeni QUITLLET

rochebobois
PARIS



Coté sièges, même idée : assise, dossier et accoudoirs semblent issus d'une division cellulaire, comme en un corps en croissance. Et dans cette logique, l'assise est en suspension au-dessus du piétement fuselé aux références scandinaves.

The chairs play on the same idea: seat, back and armrests appear to have formed through cell division, as in a growing body. Building on this theme, the seat seems to float above the tapered, Scandinavian-style leg.

Referente a los asientos, misma idea: asiento, respaldo y apoyabrazos asemejan una división celular, como un cuerpo en crecimiento. Bajo esta lógica, el asiento está en suspensión sobre un pie afilado de referencias escandinavas.



Ce bridge est certifié FSC™ 100% : le bois provient de forêts certifiées FSC™ gérées responsablement.

This bridge is certified FSC™ 100% : the wood comes from FSC™ certified forests responsibly managed.

Este bridge esta certificado FSC™ 100% : la madera proviene de bosques certificados FSC™ gestionados responsablemente.

Collection PULP

rochebobois
PARIS

design Eugeni QUITLLET



Bridge avec structure en frêne teinté ou laqué, coque rembourrée en multiplis avec renforts métallique recouverte de tissu, de cuir ou de tissu aspect cuir.

Dining armchair with structure in stained or lacquered ash wood, padded shell in plywood with metallic reinforcement upholstered in fabric, leather, or leather-like fabric.

Bridge con estructura de fresno tintado o lacado, carcasa acolchada en multilaminado con refuerzos metálicos revestida de tela, piel o tela aspecto piel.

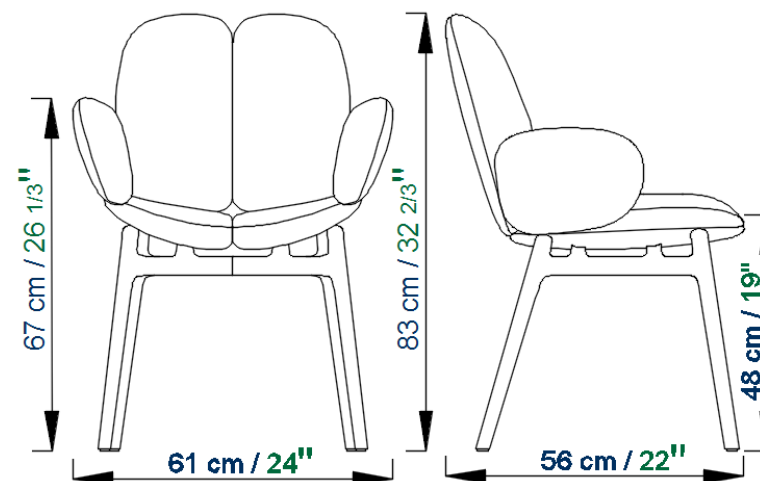

Collection PULP

design Eugeni QUITLLET

rochebobois
PARIS

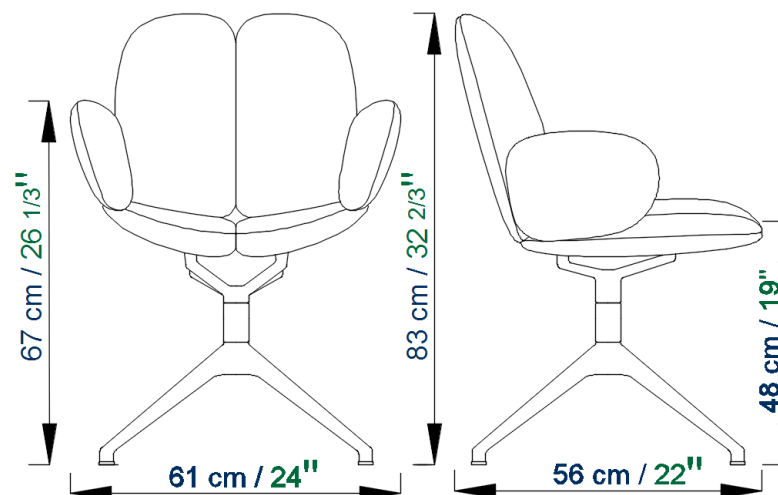

Bridge pivotant, coque en contreplaqué rembourré recouverte de tissu de cuir ou de tissu aspect cuir. Piètement central à 4 branches en métal laqué noir.

Pivoting dining armchair, padded shell in plywood upholstered in fabric, leather, or leather-like fabric. Central leg with 4 branches in metal with black lacquer finish.

Bridge pivotante, carcasa realizada en contrachapado acolchada revestida de tela, piel o tela aspecto piel. Base central con 4 patas en aspa de metal lacado negro.



Ce bridge est certifié FSC™ 100% : le bois provient de forêts certifiées FSC™ gérées responsablement.

This bridge is certified FSC™ 100% : the wood comes from FSC™ certified forests responsibly managed.

Este bridge esta certificado FSC™ 100% : la madera proviene de bosques certificados FSC™ gestionados responsablemente.

Collection PULP

design Eugeni QUITLLET

rochebobois
PARIS

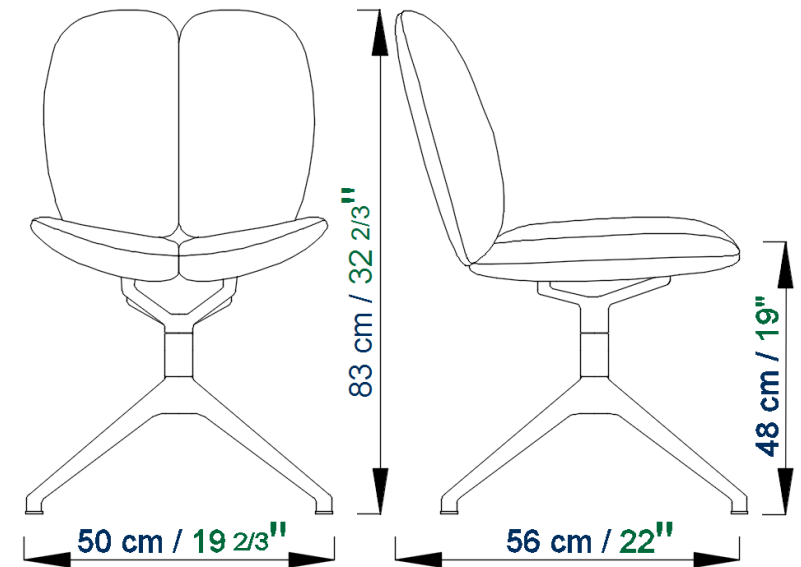

Chaise pivotante, coque en contreplaqué rembourré recouverte de tissu de cuir ou de tissu aspect cuir. Piètement central à 4 branches en métal laqué noir.

Pivoting chair, padded shell in plywood upholstered in fabric, leather, or leather-like fabric. Central leg with 4 branches in metal with black lacquer finish.

Silla pivotante, carcasa realizada en contrachapado acolchada revestida de tela, piel o tela aspecto piel. Base central con 4 patas en aspa de metal lacado negro.



Cette chaise est certifiée FSC™ 100% : le bois provient de forêts certifiées FSC™ gérées responsablement.

This chair is certified FSC™ 100% : the wood comes from FSC™ certified forests responsibly managed.

Esta silla esta certificada FSC™ 100% : la madera proviene de bosques certificados FSC™ gestionados responsablemente.