

GAMBIT

rochebobois
PARIS

design : Philippe BOUIX



GAMBIT

design : Philippe BOUIX

rochebobois
PARIS



GAMBIT

rochebobois
PARIS

design : Philippe BOUIX



INFORMATIONS TECHNIQUES / TECHNICAL SPECIFICATIONS / CARACTERISTICAS TECNICAS:

Structure : Mutiplis de bouleau et sapin

Suspension : Sangles élastiques

Garnissage assise : Mousse PF 45 kg/m³ et Ouate 100 gr/m²

Garnissage dossier : Mousses bi-densité PF 25 et 30 kg/m³, Olmosoft 25 kg/m³ et ouate 100 gr/m²

Garnissage accoudoir : Mousse bi-densité T 50 et 40 kg/m³

Piètement : Métal finition Bronze

Structure: Birch and fir plywood

Suspension: Elastic straps

Seat cushions: PF foam 45 kg/m³ and batting 100 gr/m²

Back cushions: Bi-density PF foam 25 and 30 kg/m³, Olmosoft foam 25 kg/m³ and batting 100 gr/m²

Armrest: Bi-density T foam 50 and 40 kg/m³

Base: Metal with bronze finish

Estructura : Multilaminado de álamo y abeto

Suspensión: Cinchas elasticas

Relleno asiento: Espuma PF 45 kg/m³ y guata 100 gr/m²

Relleno respaldo: Espuma PF bi-densidad 25 y 30 kg/m³, Olmosoft 25 kg/m³ y guata 100 gr/m²

Relleno apoyabrazos: Espuma T bi-densidad 50 y 40 kg/m³

Patas: Metal acabado bronce

OBSERVATIONS / OBSERVATIONS / OBSERVACIONES:

- Fabrication européenne
- Coutures gros fil 2,2 mm
- Modèle réalisable dans de nombreuses qualités de cuirs

- Manufactured in Europe
- Large stitching with 2,2 mm thread
- Model available in many leathers

- Fabricacion europea
- Costuras de hilo de 2,2 mm de grosor
- Modelo realizado en numerosas calidades de pieles

GAMBIT

design : Philippe BOUIX

GRAND CANAPE 3 PLACES
LARGE 3-SEAT SOFA
GRAN SOFA 3 PLAZAS

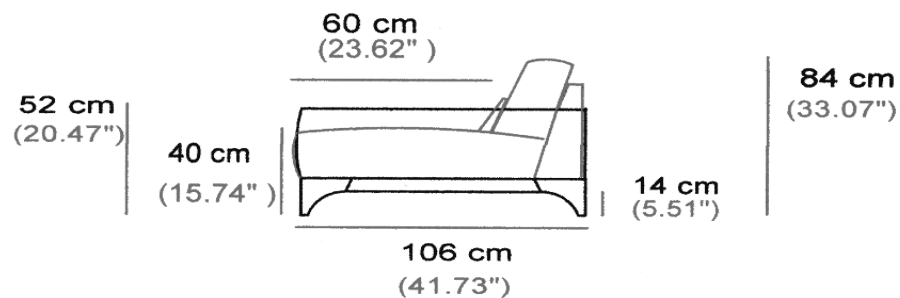
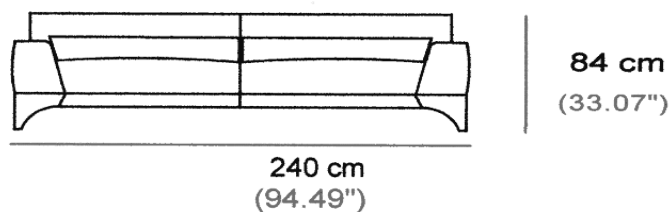
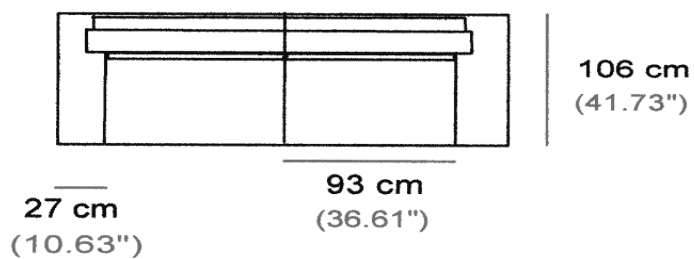

CANAPE 3 PLACES
3-SEAT SOFA
SOFA 3 PLAZAS

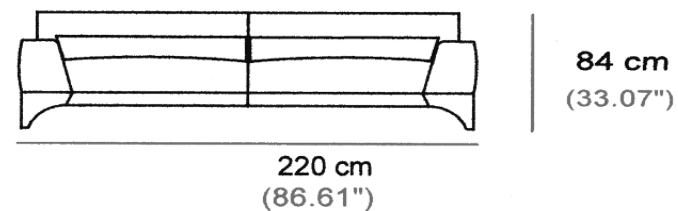
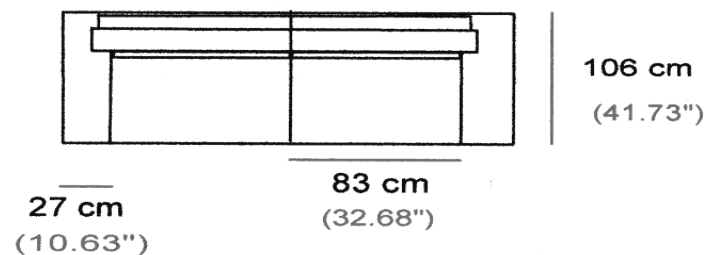

GAMBIT

design : Philippe BOUIX

CANAPE 2.5 PLACES
2.5-SEAT SOFA
SOFA 2.5 PLAZAS

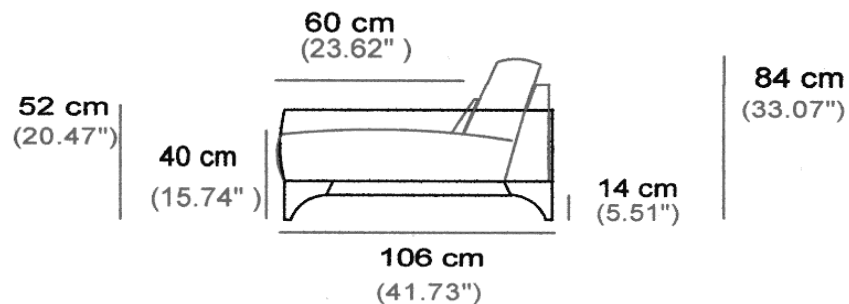
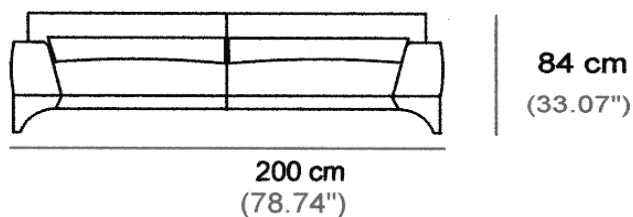
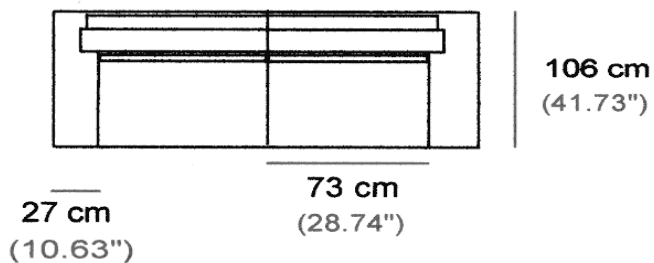

CANAPE 2 PLACES
2-SEAT SOFA
SOFA 2 PLAZAS

