

Collection INTERMEDE

rochebobois
PARIS

design Maurizio MANZONI



TU116

Collection INTERMEDE

rochebobois
PARIS

design Maurizio MANZONI



TABLE BASSE - COCKTAIL TABLE - MESA DE CENTRO

Collection INTERMEDE

rochebobo
PARIS

design Maurizio MANZONI



Table basse avec plateau supérieur en verre fumé ou céramique et plateau inférieur laqué mat (nombreux coloris). Structure en acier laqué noir.

Cocktail table with upper tray in smoked glass or in ceramic and lower tray in matte lacquer (many colours available). Structure in lacquered steel col. black.

Mesa de centro con sobre superior en cristal ahumado o de cerámica y sobre inferior lacado mate (varios colores). Estructura de acero lacado en negro.

34 cm / 13,38"

100 cm – 39,37"



100 cm – 39,37"

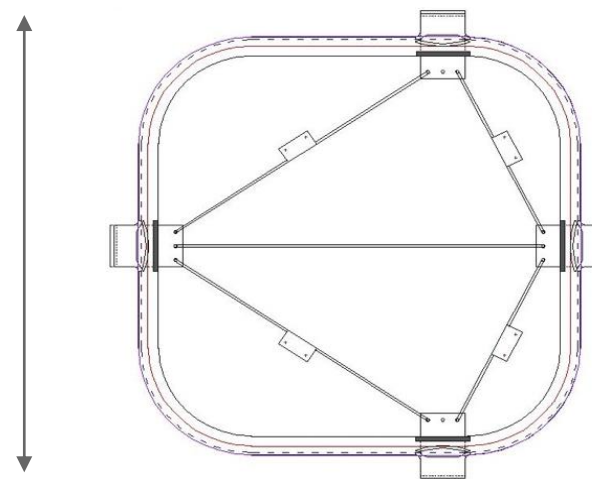

Collection INTERMEDE

rochebobo
PARIS

design Maurizio MANZONI



Table basse avec plateau supérieur en verre fumé ou céramique et plateau inférieur laqué mat (nombreux coloris). Structure en acier laqué noir.

Cocktail table with upper tray in smoked glass or in ceramic and lower tray in matte lacquer (many colours available). Structure in lacquered steel col. black.

Mesa de centro con sobre superior en cristal ahumado o de cerámica y sobre inferior lacado mate (varios colores). Estructura de acero lacado en negro.

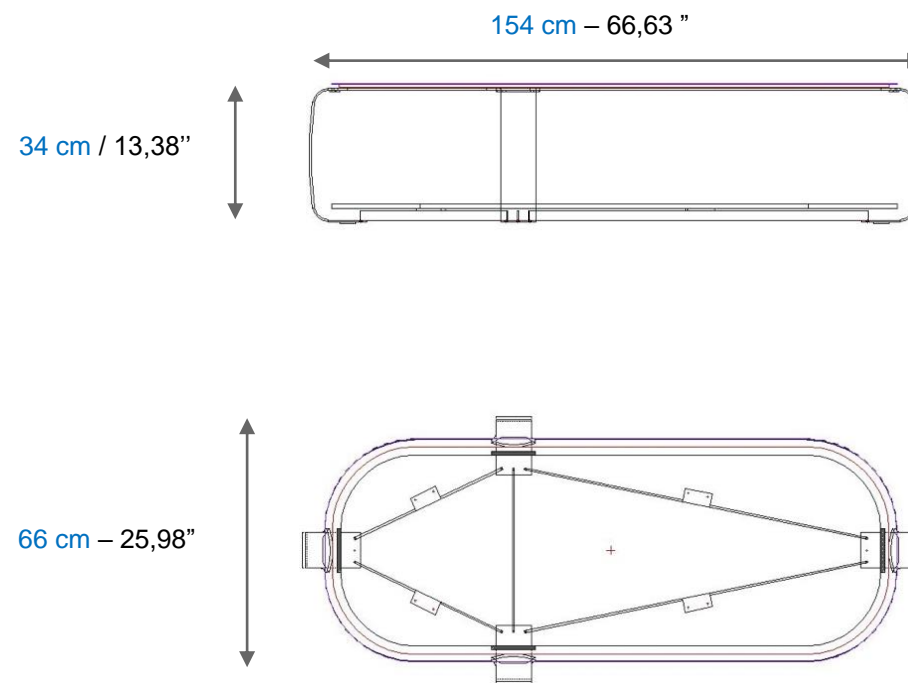

Collection INTERMEDE

rochebobo
PARIS

design Maurizio MANZONI



Table basse avec plateau supérieur en verre fumé ou céramique et plateau inférieur laqué mat (nombreux coloris). Structure en acier laqué noir.

Cocktail table with upper tray in smoked glass or in ceramic and lower tray in matte lacquer (many colours available). Structure in lacquered steel col. black.

Mesa de centro con sobre superior en cristal ahumado o de cerámica y sobre inferior lacado mate (varios colores). Estructura de acero lacado en negro.

34 cm / 13,38"

100 cm – 39,37"

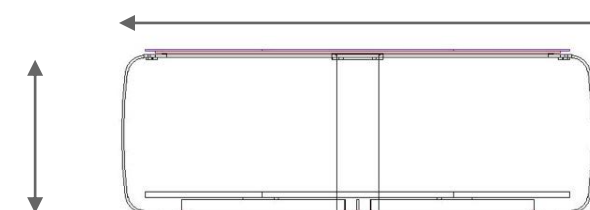

55 cm – 21,65"

